



Analog Reinvented

The Sabre ES9822 PRO is the world's highest performance 32-bit analog-to-digital (A/D) converter targeted for professional audio applications such as recording systems, mixer consoles and digital audio workstations (DAW), test equipment, instruments, audio processors, digital turntables, and consumer applications.

The ES9822 PRO has 2 integrated ADCs which use the ESS proprietary Hyperstream® II ADC Architecture, which delivers unprecedented audio sound quality and specifications, including a DNR of 128dB in mono mode and a DNR 125dB, THD+N of -117dB in 2 channel mode.

The SABRE® ADC supports synchronous SPDIF, I2S master/slave, or native DSD output. For the most demanding audio enthusiast, the ES9822 PRO is capable of outputting RAW data, allowing the user to apply their own custom handling of the data.

The ES9822 PRO comes in a small compact package and consumes less than 170mW.

The ES9822 can use preprogrammed filter coefficients to match perfectly with the SABRE PRO Series of DACs including the ES9038PRO. These complimentary filters allow for analog-digital-analog processing with the upmost audio fidelity and minimized time-domain smearing.

The Audio Signal Processor (ASP) integrated in the ADC allows for custom filtering such as RIAA presets to be implemented in the ADC, eliminating the need for re-processing later in the signal path.

The ES9822 PRO has an Ultra-Low Noise Floor Bandwidth of 200kHz. This bandwidth is up to 10 times wider than the competition, enabling higher resolution at higher sample rates.

Feature	Description
+125dB DNR 2 channel mode +128dB DNR in mono mode -117dB THD+N 2 channel mode -118dB THD+N in mono mode	Unprecedented dynamic range and ultra-low distortion
High Sample Rates	Up to PCM 768kHz, including 1.536MHz w/Double Data rates Up to DSD512
Audio Signal Processors (ASP)	Available for custom FIR filters for any applications, including RIAA
Multiple Output formats available	PCM, TDM, DSD, S/PDIF, RAW
Customizable filter characteristics	8 presets, and programmable filter coefficients for custom sound signature 2 audio signal processors for custom filter architectures and analog/digital mixing
I2C or SPI interface control	Configured by microcontroller or used as standalone
Integrated low noise ADC reference regulators	Reduced BOM cost, PCB area and improved DNR.
Low Power Consumption	Simplifies power supply design
Low Pin Count standardized Packaging	5mm x 5mm, 40 pin QFN
Ultra-Low Noise Floor Bandwidth	200kHz bandwidth enabling higher resolution at higher sample rates

APPLICATIONS

- Professional digital audio workstations audio recording
- Very high quality microphones
- High quality record turntable to USB conversion



Table of Contents

APPLICATIONS.....	1
Table of Contents	2
List of Figures	4
List of Tables	5
Functional Block Diagram.....	6
ES9822QPRO Package	7
40 QFN Pinout.....	7
40 QFN Pin List	8
Digital Features.....	9
Digital Signal Path	9
THD Compensation	9
Audio Signal Processor (ASP)	9
I2S decoder and Programmable Delay.....	11
Clip Detection.....	10
Volume Control	9
GPIO	12
GPIO Audio Data Configurations	13
Pre-Programmed Digital Filters	14
PCM Filter Frequency Response	15
Clock Distribution	20
I2S Master Clock Rate Configurations.....	23
I2S Slave Clock Rate Configurations.....	24
TDM Slave Clock Rate Configurations	25
TDM Master Clock Rate Configurations	26
DSD Master Clock Rate Configurations.....	27
Digital Audio Output Port	28
PCM Pin Connections	28
TDM Pin Connections	28
DSD Pin Connections.....	28
S/PDIF Pin Connections.....	28
RAW Pin Connections.....	29
Digital Audio Input Port.....	29
PCM Pin Connections	29
PCM Filter Impulse Response.....	30
Absolute Maximum Ratings	33
IO Electrical Characteristics.....	33
Recommended Operating Conditions.....	34
Recommended Power up/down Sequences	35

ES9822 PRO Product Datasheet



Power Consumption	36
Performance	37
Register Overview	38
I ² C Slave Interface (Device Address 0x40,0x42,0x44,0x46)	39
Read/Write Register Addresses	39
Read-only Register Addresses	39
I ² C Synchronous Slave Interface (Device Address 0x48,0x4A,0x4C,0x4E)	39
Write-only Register Addresses	39
Multi-Byte Registers	39
I ² C Slave/Synchronous Slave Interface Timing	40
SPI Slave Interface	41
Register Map	42
Register Listing	47
System Registers	47
ASP Registers	65
Delay Line Registers	70
GPIO Registers	77
ADC CH1 Registers	90
ADC CH2 Registers	95
Synchronous Slave Interface Registers	100
System Readback Registers	101
GPIO READBACK REGISTERS	103
ADC CH1 READBACK Registers	104
ADC CH2 Readback Registers	105
ES9822 PRO Reference Schematic	106
Internal Pad Circuitry	108
40 QFN Package Dimensions	110
40 QFN Top View Marking	111
Reflow Process Considerations	112
Temperature Controlled	112
Manual	113
RPC-1 Classification reflow profile	113
RPC-2 Pb-Free Process – Classification Temperatures (T _c)	114
Ordering Information	115
Addendum	116
I2S Master	116
I2S Slave	118
TDM Master	120
TDM Slave	122
Revision History	124



List of Figures

Figure 1 - ES9822 PRO Block Diagram	6
Figure 2 - 40 QFN Pinout.....	7
Figure 3 - Digital Signal Path	9
Figure 4 - ES9822 PRO Clock Distribution.....	20
Figure 6 - Recommended Power up/down Sequences	35
Figure 7 - I2C Slave Control Interface Timing Diagram.....	40
Figure 8 - SPI Timing Diagrams	41
Figure 9 - ES9822QPRO Reference schematic for normal operation	106
Figure 10 - Reference schematic ADC input stage for Single Ended (S/E) and differential input	107
Figure 11 - ES9311Q Reference voltage regulator schematic	107
Figure 12 - 40 QFN Package Dimensions	110
Figure 13 - ES9822 PRO QFN Marking	111
Figure 14 - IR/Convection Reflow Profile (IPC/JEDEC J-STD-020D.1)	112



List of Tables

Table 1 - 40 QFN Pin List	8
Table 2 – Standard GPIO Functions.....	12
Table 3 - GPIO Audio Data Configurations.....	13
Table 4 - Pre-Programmed Digital Filters	14
Table 5 - PCM Filter Frequency Response	19
Table 7 - I2S Master Clock Rate Configurations	23
Table 8 - I2S Slave Clock Rate Configurations	24
Table 9 - TDM Slave Clock Rate Configurations	25
Table 10 - TDM Master Clock Rate Configurations	26
Table 11 - DSD Master Clock Rate Configurations	27
Table 6 - PCM Pin Connections	28
Table 7 - TDM Pin Connections.....	28
Table 8 - DSD Pin Connections.....	28
Table 9 - S/PDIF Pin Connections.....	28
Table 10 - RAW Pin Connections	29
Table 11 - PCM Pin Connections	29
Table 12 - PCM Filter Impulse Response.....	32
Table 13 - Absolute Maximum Ratings.....	33
Table 14 - IO Electrical Characteristics	33
Table 15 - Recommended Operating Conditions	34
Table 16 - 49.152Mhz MCLK Power Consumption	36
Table 17 - 24.576MHz MCLK Power Consumption.....	36
Table 18 - Performance.....	37
Table 19 - I2C Addresses.....	38
Table 20 - I2C Slave Control Interface Timing Definitions.....	40
Table 21 - Register Map	46
Table 22 - Internal Pad Circuitry	109
Table 23 - RPC-1 Classification reflow profile	113
Table 24 - RPC-2 Pb-Free Process.....	114
Table 25 - Ordering Information.....	115



Functional Block Diagram

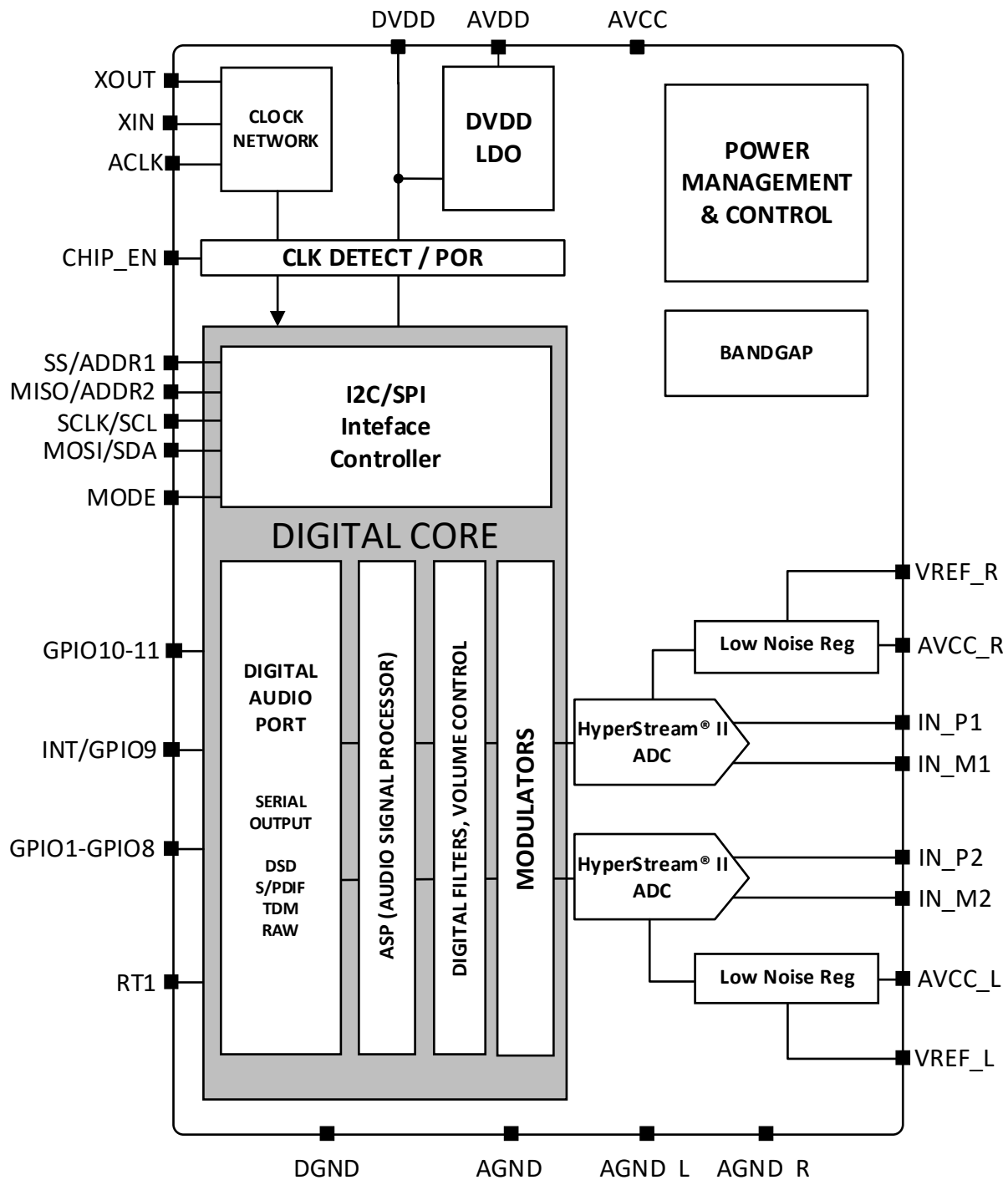
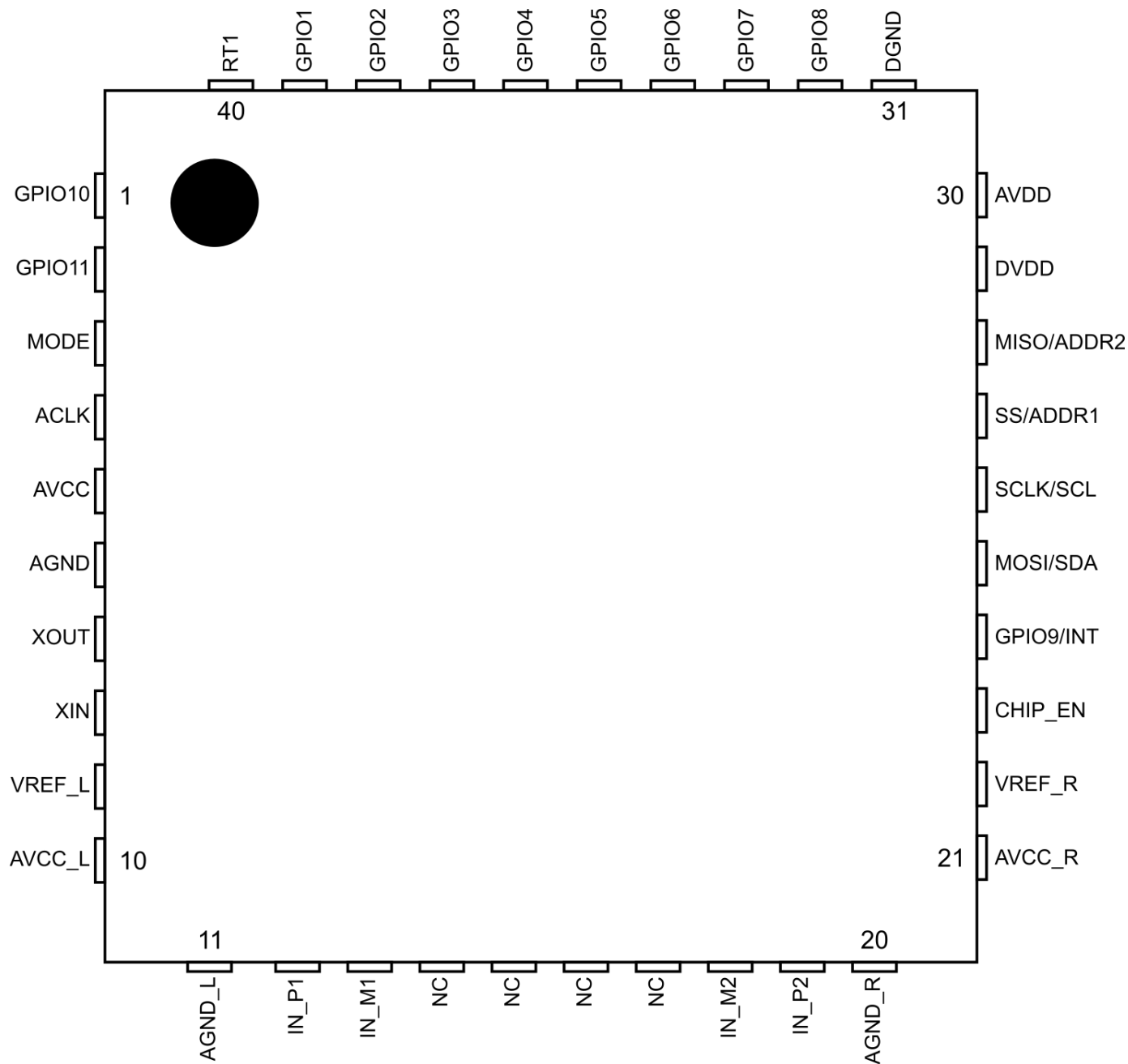

Figure 1 - ES9822 PRO Block Diagram



ES9822QPRO Package

40 QFN Pinout



ES9822Q

(Top View)

Figure 2 - 40 QFN Pinout



40 QFN Pin List

Pin	Name	Pin Type	Reset State	Pin Description
1	GPIO10	I/O	HiZ	General I/O w/extended functions
2	GPIO11	I/O	HiZ	General I/O w/extended functions
3	MODE	I/O	HiZ	I2C or SPI Control selection
4	ACLK	AI	HiZ	Auxiliary Clock Input
5	AVCC	Power	Power	4.5V Supply
6	AGND	Ground	Ground	Analog Ground
7	XOUT	AO	HiZ	Crystal Output
8	XIN ¹	AI	HiZ	Crystal Input/Oscillator Input
9	VREF_L	Power	Power	Low Noise reference for on-chip regulator, left side
10	AVCC_L	Power	Power	ADC reference voltage (4.5V Supply)
11	AGND_L	Ground	Ground	Analog Ground
12	IN_P1	AI	HiZ	ADC Channel 1 differential positive (+) input
13	IN_M1	AI	HiZ	ADC Channel 1 differential negative (-) input
14	NC	-	-	No Connect
15	NC	-	-	No Connect
16	NC	-	-	No Connect
17	NC	-	-	No Connect
18	IN_M2	AI	HiZ	ADC Channel 2 differential negative (-) input
19	IN_P2	AI	HiZ	ADC Channel 2 differential positive (+) input
20	AGND_R	Ground	Ground	Analog Ground
21	AVCC_R	Power	Power	ADC reference voltage (4.5V Supply)
22	VREF_R	Power	Power	Low Noise reference for on-chip regulator, right side
23	CHIP_EN	I/O	HiZ	Active-high chip enable.
24	GPIO9	I/O	HiZ	General I/O w/extended functions, including INT (INTERRUPT)
25	MOSI/SDA	I/O	HiZ	Serial communication, MOSI(SPI), SDA(I2C), controlled by MODE
26	SCLK/SCL	I/O	HiZ	Serial Clock, SCLK (SPI), SCL (I2C), controlled by MODE
27	SS/ADDR1	I/O	HiZ	Serial communication, SS(SPI), SCL (I2C), controlled by MODE
28	MISO/ADDR2	I/O	HiZ	Serial communication, MISO(SPI), ADDR2 (I2C), controlled by MODE
29	DVDD	Power	Power	Digital Core Supply. Internally Supplied
30	AVDD	Power	Power	3.3V, I/O Supply
31	DGND	Ground	Ground	Digital Core Ground
32	GPIO8	I/O	HiZ	General I/O w/extended functions, Serial Data 8
33	GPIO7	I/O	HiZ	General I/O w/extended functions, Serial Data 7
34	GPIO6	I/O	HiZ	General I/O w/extended functions, Serial Data 6
35	GPIO5	I/O	HiZ	General I/O w/extended functions, Serial Data 5
36	GPIO4	I/O	HiZ	General I/O w/extended functions, Serial Data 4
37	GPIO3	I/O	HiZ	General I/O w/extended functions, Serial Data 3
38	GPIO2	I/O	HiZ	General I/O w/extended functions, Serial Data 2
39	GPIO1	I/O	HiZ	General I/O w/extended functions, Serial Data 1
40	Package Pad ²	-	-	Not electrically connected, used for heat dissipation. Connect to DGND

Table 1 - 40 QFN Pin List

¹ MCLK can be connected to XIN or ACLK

² Pin 41 is the package pad. See 40 QFN package dimensions for sizing. Connect to DGND.

Digital Features

Digital Signal Path

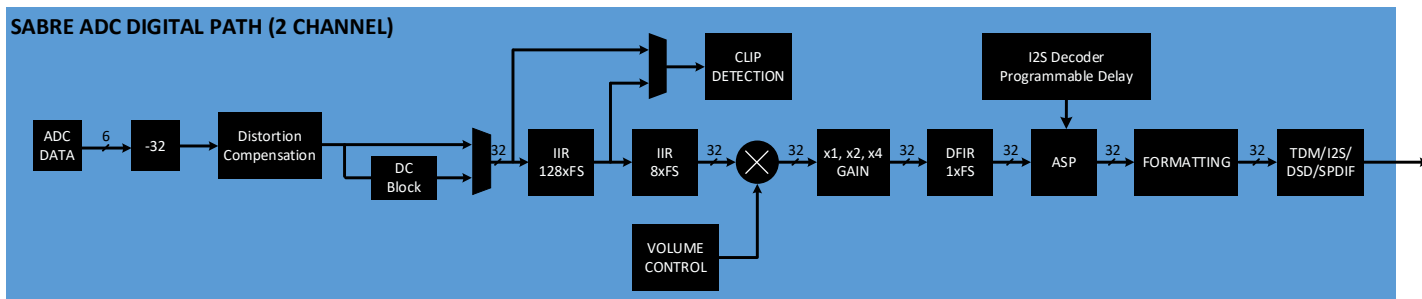

Figure 3 - Digital Signal Path

THD Compensation³

THD Compensation minimizes the non-linearities of the ADCs. The ES9822 PRO can help compensate for system second and third harmonic distortion.

THD compensation can be enabled or bypassed by setting `ADCx_ENABLE_THD_COMP` for each channel

THD Compensation Enable Registers

- Register 102 [0]: ADC1_ENABLE_THD_COMP
- Register 119 [0]: ADC2_ENABLE_THD_COMP
- Register 136 [0]: ADC3_ENABLE_THD_COMP
- Register 153 [0]: ADC4_ENABLE_THD_COMP

For best results, compensation coefficients should be tuned for each device in-situ.

DC Block

The ES9842 has a built in DC blocking filter. Please ask for an application note that is available showing an improved filter using the built in ASPs.

Volume Control

This volume control is intended for use during audio playback. Each channel can be digitally attenuated from 0dB to -84dB in 0.5dB steps. The attenuation circuit automatically uses micro-stepping between 0.5dB register settings so that no switching noise occurs during the volume control transition. When a new volume level is set, the attenuation circuit will ramp softly to the new level. Each 0.5dB step takes up to 64 intermediate steps depending on the `CHx VOLUME RATE` setting.

Volume Level Configuration Registers

- Register 109-110: ADC CH1 VOLUME
- Register 126-127: ADC CH2 VOLUME

Volume Rate Configuration Registers

- Register 111: ADC CH1 VOLUME RATE
- Register 128: ADC CH2 VOLUME RATE

³ For more information on using THD Compensation, please reference the THD Compensation Application Note. Available from your local FAE upon request.



Audio Signal Processor (ASP) ⁴

The ES9822 PRO includes 2 stereo audio signal processors (ASP) which can be used to implement both custom filter coefficients as well as custom filter architectures. This feature may also be used to implement a programmable equalizer (PEQ) and other applications.

See [Digital Signal Path](#) diagram for location in the data path.

ASP Registers:

- *Registers 35-58*

Clip Detection⁵

If the peak level of the ES9822 PRO device's input audio stream rises above the programmed ADC#_CLIP_LEVEL value, the corresponding clip flag will be set. The clip flag will stay set until it is cleared with INTERRUPT_CLEAR_CH#_CLIP_DETECTION. Any of the GPIO pins can be configured to output the state of any of the clip flags if INTERRUPT_MASK_CH#_CLIP_DETECTION is set for the corresponding channel.

Clipping Level Registers:

- *Register 106: ADC CH1 PEAK DETECTOR LEVEL*
- *Register 123: ADC CH2 PEAK DETECTOR LEVEL*

Clipping Interrupt Clear Registers:

- *Register 27 [5]: INTERRUPT_CLEAR_CH2_CLIP_DETECTION*
- *Register 27 [4]: INTERRUPT_CLEAR_CH1_CLIP_DETECTION*

Clipping Interrupt Mask Registers

- *Register 27 [1]: INTERRUPT_MASK_CH2_CLIP_DETECTION*
- *Register 27 [0]: INTERRUPT_MASK_CH1_CLIP_DETECTION*

The GPIO READBACK register values 4'd4 – 4'd7 output the clip interrupt state for CH1 & CH2, respectively. The corresponding channel bit in Register 27[3:0] INTERRUPT_CLEAR_CH#_CLIP_DETECTION needs to be set for the GPIO to output the flag value.

⁴ For help with designing with the ASP, please reference the ASP GUIDE Application Note. Available from your local FAE upon request.

⁵ For further information on using Clip Detection, please reference the Clip Detector Configuration Application Note. Available from your local FAE upon request



I2S decoder and Programmable Delay

The ES9822 PRO has a built in I2S decoder that can be mixed with the ASP. A programmable delay is also included to help with phase correction when mixing.

I2S Decoder Configuration Registers:

- *Registers 59-60:* I2S DECODER CONFIG

Programmable Delay Registers:

- *Register 62-61 [9]:* ENABLE_CLK_DL
- *Registers 62-61 [8:0]:* PROG_DELAY_LINE

Configuration pins for I2S decoder:

- *GPIO 1:* BCK
- *GPIO 2:* WS
- *GPIO 5:* DATA (would be configured as an AUX Input through the GPIO configuration)

Mixing is accomplished using the ASP registers expanded on under the Volume Control

This volume control is intended for use during audio playback. Each channel can be digitally attenuated from 0dB to -84dB in 0.5dB steps. The attenuation circuit automatically uses micro-stepping between 0.5dB register settings so that no switching noise occurs during the volume control transition. When a new volume level is set, the attenuation circuit will ramp softly to the new level. Each 0.5dB step takes up to 64 intermediate steps depending on the *CHx VOLUME RATE* setting.

Volume Level Configuration Registers

- *Register 109-110:* ADC CH1 VOLUME
- *Register 126-127:* ADC CH2 VOLUME

Volume Rate Configuration Registers

- *Register 111:* ADC CH1 VOLUME RATE
- *Register 128:* ADC CH2 VOLUME RATE

Audio Signal Processor (ASP) section.



GPIO

<i>gpio#_config</i>	<i>function</i>	<i>I/O Direction</i>
0	analog shutdown	Shutdown (default)
1	Aux Inputs	Inputs
2	Aux Outputs	Output
3	RAW data outputs	Output
4	Interrupt Ch1 clip	Output
5	Interrupt Ch2 clip	Output
6	Reserved	-
7	Reserved	-
8	SPDIF data output	Output
9	PWM1	Output
10	PWM2	Output
11	PWM3	Output
12	CLK IADC	Output
13	CLK ADC	Output
14	1'b0	Output
15	1'b1	Output

Table 2 – Standard GPIO Functions

For configuring pins as inputs, outputs, or Input/Outputs:

- Input pin
 - GPIOxx_IE = 1'b1 (Input Enable), Registers 87-86
 - GPIOxx_OE = 1b'0 (Input Enable), Registers 89-88
- Output pin
 - GPIOxx_IE = 1'b0
 - GPIOxx_OE = 1'b1
- In/Out pin (Master Mode)
 - GPIOxx_IE = 1'b1
 - GPIOxx_OE = 1'b1

In Master mode GPIO1 & GPIO 2 should be configured as In/Out pins

Data pins may be re-mapped to other GPIO via the System Registers. When utilizing GPIO pins 4-6, it is important to enable the TDM_GPIO456 bit.

GPIO 4-6 TDM Enable Register

- *Register 11 [7]:* TDM_GPIO456

TDM GPIO Re-mapping Registers

- *Register 12 [6:5]:* TDM_LINE_SEL_CH1
- *Register 13 [6:5]:* TDM_LINE_SEL_CH2

GPIO Configuration Registers

- Register 74: GPIO1/2 CONFIG
- Register 75: GPIO3/4 CONFIG
- Register 76: GPIO5/6 CONFIG
- Register 77: GPIO7/8 CONFIG
- Register 78: GPIO9/10 CONFIG
- Registers 80-91



GPIO Audio Data Configurations

The following table shows the configurations possible using GPIO#_config Aux Inputs, Aux Outputs, and RAW data outputs on the ES9822 PRO. In certain modes, the data output pins may be re-mapped to GPIO pins 4-6. These scenarios are labeled “[optional]” in the table below. The channel order may also be changed in these modes. Although it is not denoted in the table, the data output in Slave Mode may also be re-mapped to the same pins.

GPIO #	1 (AUX Inputs) (Slave mode)	2 (AUX Outputs) (Master mode)				3 (Raw Data Output)
GPIO1	I2S/TDM in BCK, DSD in clock	I2S master BCK	TDM master BCK	DSD master clock out	PDM clock	Raw Data Clock output
GPIO2	I2S/TDM in WS	I2S master WS	TDM master WS			Raw Data[0] out
GPIO3		I2S out DATA [optional] ⁶ (default)	TDM out DATA [optional] ⁶ (default)	DSD out DATA ⁷	PDM out DATA	Raw Data[1] out
GPIO4	TDM cascade data input Cascade mode for multiple devices	I2S out DATA [optional] ⁶	TDM out DATA [optional] ⁶	DSD out DATA ⁷	PDM out DATA	Raw Data[2] out
GPIO5	I2S decoder data input	I2S out DATA [optional] ⁶	TDM out DATA [optional] ⁶	DSD out DATA ⁷		Raw Data[3] out
GPIO6		I2S out DATA [optional] ⁶	TDM out DATA [optional] ⁶	DSD out DATA ⁷		Raw Data[4] out
GPIO7						Raw Data[5] out
GPIO8						Raw Data[6] out
GPIO9		INTERRUPT (Triggered by the 2 channels)				INTERRUPT
GPIO10						
GPIO11						

Table 3 - GPIO Audio Data Configurations

⁶ Using the [TDM GPIO Re-mapping Registers](#), the data may be configured to output GPIO pins 4-6. In order to do this [Register 11 \[7\]](#): TDM_GPIO456 must also be enabled.

⁷ The DSD channel order can be changed via [Register 19: DSD_DATA_OUTPUT_MAPPING](#).



Pre-Programmed Digital Filters

The ES9822 PRO has 8 pre-programmed digital filters. The following table shows the measured latency of each filter at varying sample rates.

Digital Filter	Delay(us) @ fs=44.1kHz	Delay(us) @ fs=176.4kHz
Minimum phase (default)	109us	25.1us
Linear Phase Apodizing	771us	193.8us
Linear Phase Fast Roll-Off	774us	194.5us
Linear Phase Fast Roll-Off Low Ripple	765us	192.4us
Linear Phase Slow Roll-Off	150.3us	38.52us
Minimum Phase fast roll-off	96.17us	21.96us
Minimum Phase slow roll-off	69.86us	16.87us
Minimum Phase Slow roll-off low dispersion	293.4us	74.18us

Table 4 - Pre-Programmed Digital Filters



PCM Filter Properties

The following filter properties were obtained from software simulations of these filters.

Linear Phase Apodizing					
Parameter	Conditions	MIN	TYP	MAX	UNIT
Pass band	-3dB			0.44 x fs	Hz
Stop band	-108dB	0.5 x fs			Hz
Group Delay			33/fs		s
Flatness (ripple)	± 0.0014				dB

Linear Phase Fast Roll-off					
Parameter	Conditions	MIN	TYP	MAX	UNIT
Pass band	-3dB			0.49 x fs	Hz
Stop band	-115dB	0.54 x fs			Hz
Group Delay			33/fs		s
Flatness (ripple)	± 0.0017				dB

Linear Phase Fast Roll-off Low Ripple					
Parameter	Conditions	MIN	TYP	MAX	UNIT
Pass band	-3dB			0.5 x fs	Hz
Stop band	-82dB	0.54 x fs			Hz
Group Delay			33/fs		s
Flatness (ripple)	$\pm 4.87 \times 10^{-5}$				dB

Linear Phase Slow Roll-Off					
Parameter	Conditions	MIN	TYP	MAX	UNIT
Pass band	-3dB			0.49 x fs	Hz
Stop band	-81dB	0.81 x fs			Hz
Group Delay			5.625/fs		s
Flatness (ripple)	$\pm 1.67 \times 10^{-4}$				dB



Minimum Phase Fast Roll-off					
Parameter	Conditions	MIN	TYP	MAX	UNIT
Pass band	-3dB			0.49 x fs	Hz
Stop band	-96dB	0.54 x fs			Hz
Group Delay			3.25/fs		s
Flatness (ripple)	±0.6814				dB

Minimum Phase Slow Roll-off					
Parameter	Conditions	MIN	TYP	MAX	UNIT
Pass band	-3dB			0.48 x fs	Hz
Stop band	-83dB	0.81 x fs			Hz
Group Delay			2.12/fs	2.34/fs	s
Flatness (ripple)	±0.0036				dB

Minimum Phase Slow Roll-off Low Dispersion					
Parameter	Conditions	MIN	TYP	MAX	UNIT
Pass band	-3dB			0.48 x fs	Hz
Stop band	-83dB	0.81 x fs			Hz
Group Delay			12/fs		s
Flatness (ripple)	±0.005				dB



PCM Filter Frequency Response

The following frequency responses were obtained from software simulations of these filters. Simulation sample rate is 44.1kHz.

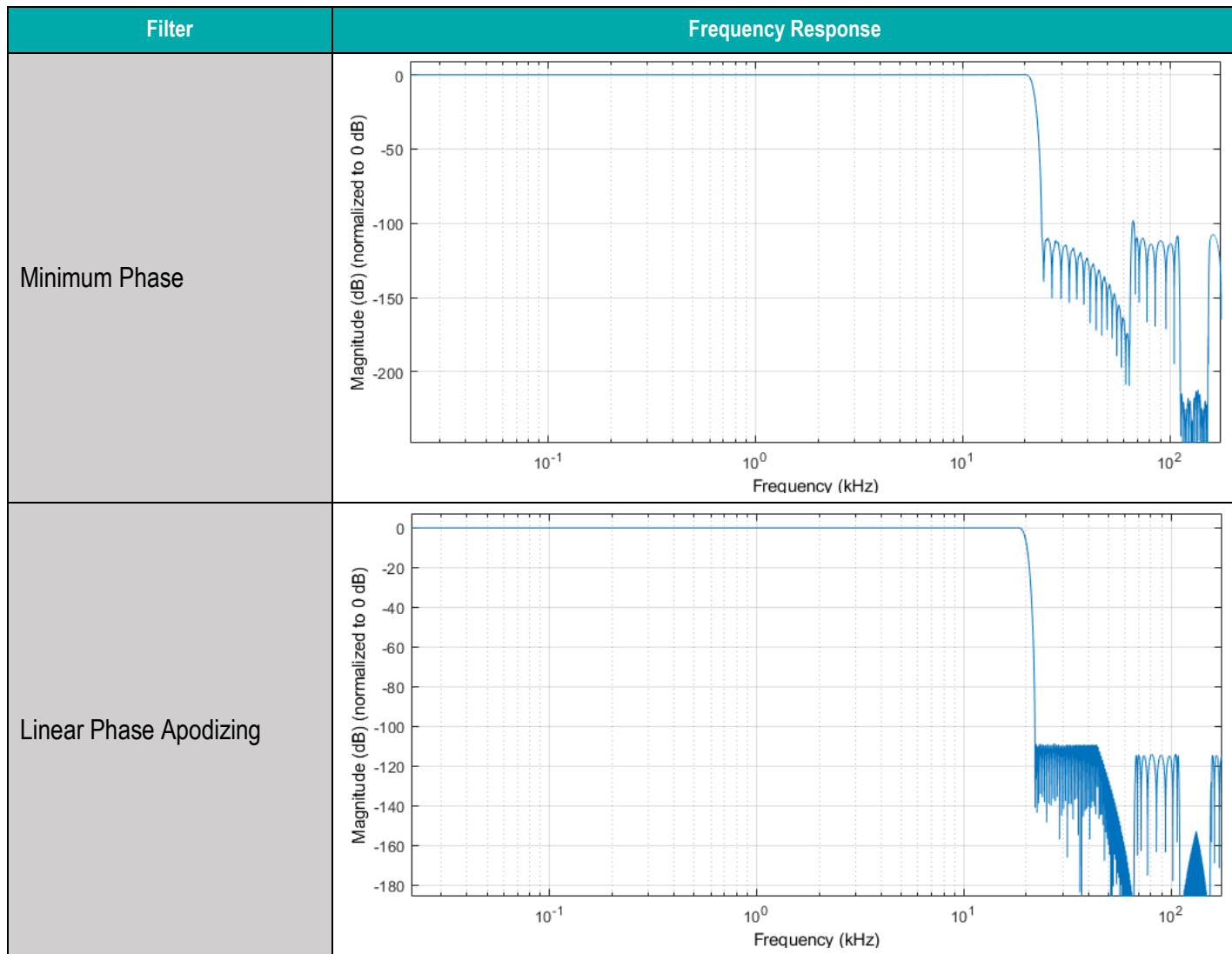

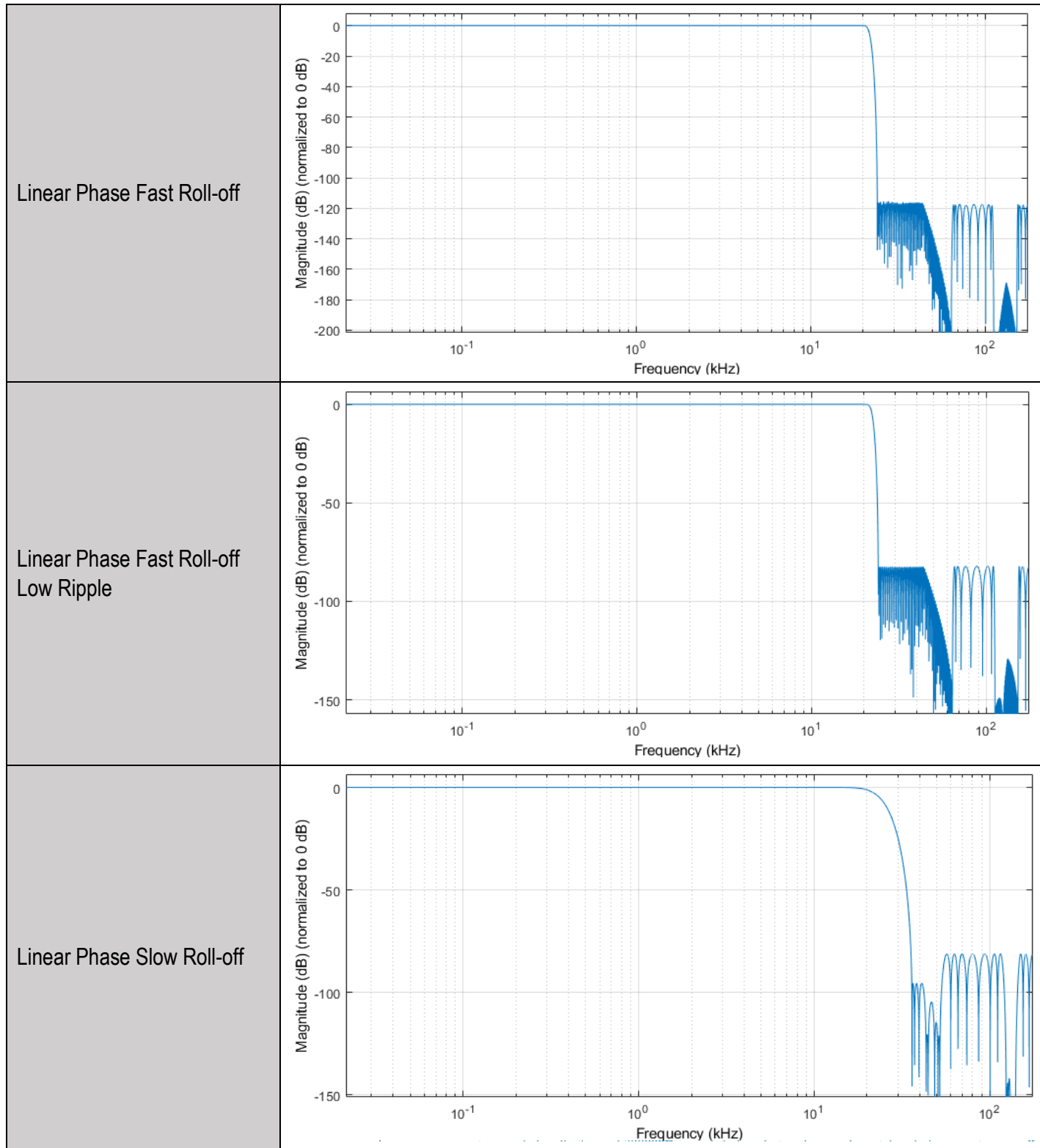

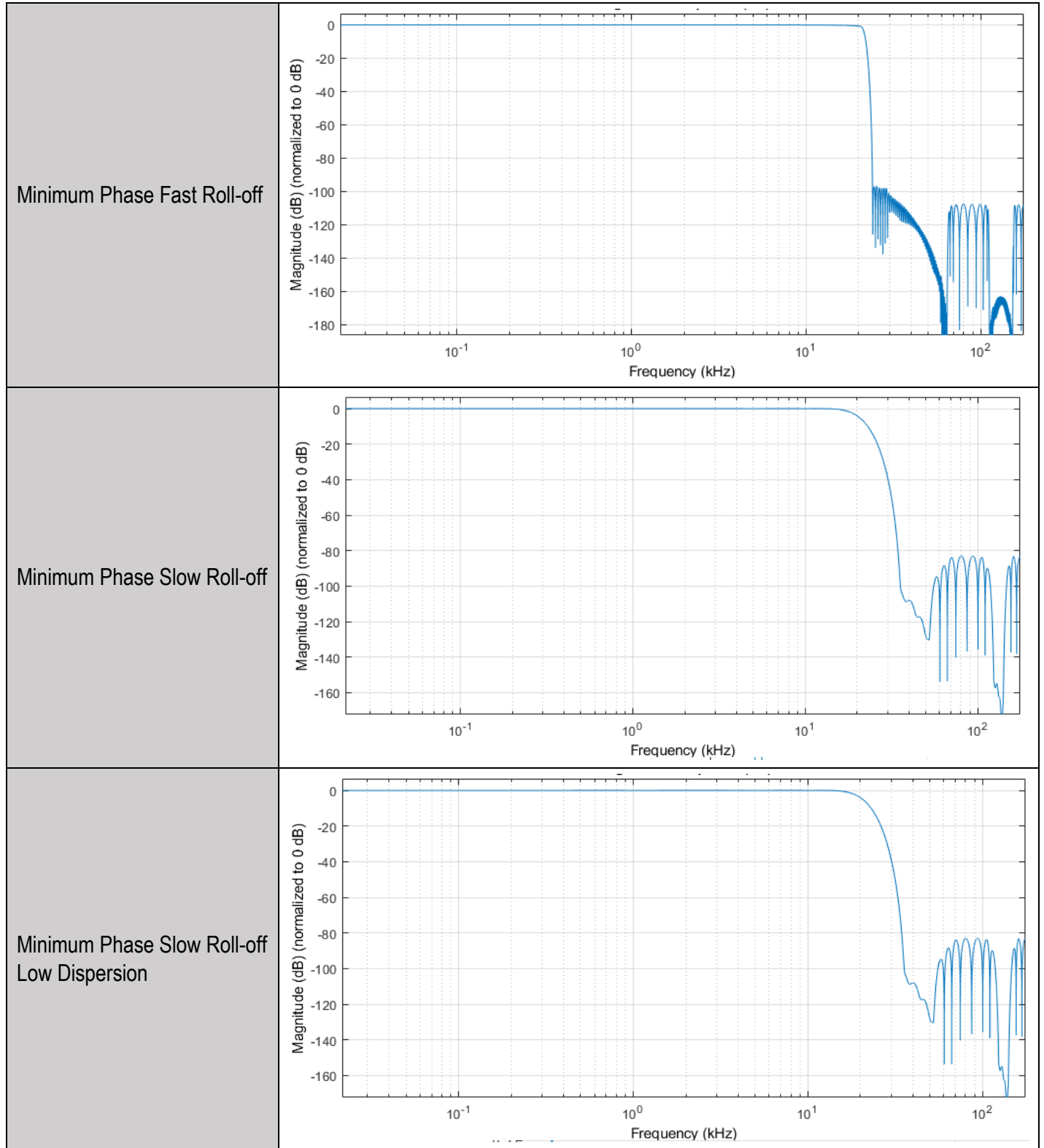

Table 5 - PCM Filter Frequency Response



Clock Distribution

The ES9822 PRO includes features for selecting and manipulating the input clock source.

The minimum MCLK frequency is 22.579 MHz.

When using 24.576 MHz or 22.579 MHz BCK, it is preferable to use GPIO4-6 as the data output.

- Register 74-91 (GPIOx/x_CONFIG) – set desired GPIO as AUX output and enable output mode
- Reg 12-15 [6:5] (TDM_LINE_SEL_CHx) – change TDM Line Select to desired GPIO
- Reg 11 [7] (TDM_GPIO456) – Enable TDM on GPIO456

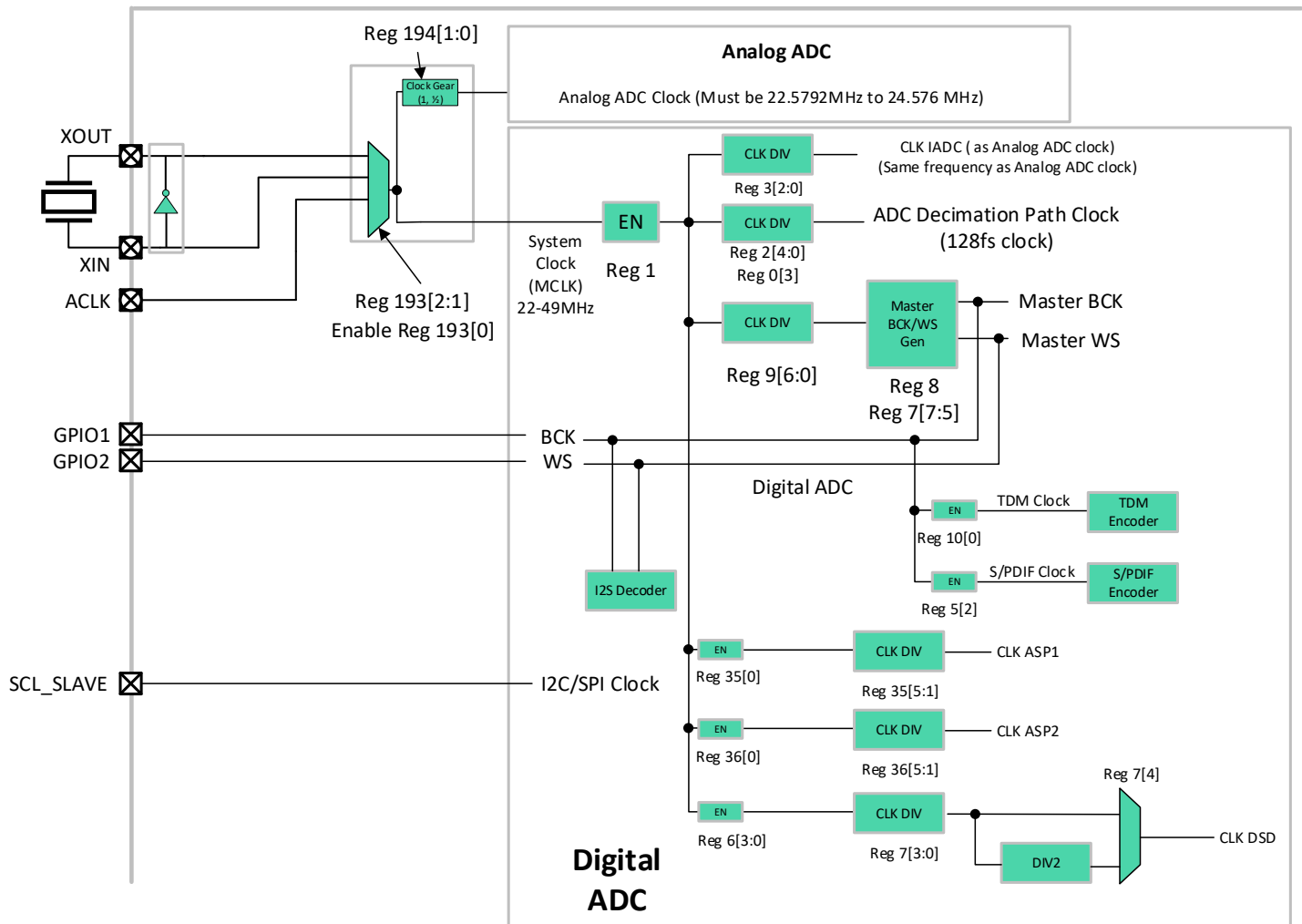

Figure 4 - ES9822 PRO Clock Distribution



The following list shows the various clocks of the ES9822 and the associated registers for configuration.

Analog ADC Clock

ADC clock must be maintained to be between 22.5792MHz & 24.576MHz

- Reg 194[0] (SEL_CLK_DIV)
- Reg 193[2:1] (SEL_SYSCLK_IN)
- Reg 193[0] (EN_ANA_CLKIN)

IADC Clock (Digital Input ADC Clock)

Should be set to the same clock frequency as the analog ADC clock, sampling Analog ADC

- Reg 3[2:0] (SELECT_IADC_NUM)
 - Set this so it matches Analog ADC clock of 22.5792 or 24.576MHz
- Reg 1
 - Dependent on channels required
- Reg 193[2:1] (SEL_SYSCLK_IN)
- Reg 193[0] (EN_ANA_CLKIN)

ADC Decimation Path Clock

- Reg 2[4:0] (SELECT_ADC_NUM)
- Reg 1
 - Dependent on channels required
- Reg 9[6:0] (SELECT_I2S_TDM_NUM)
- Reg 193[2:1] (SEL_SYSCLK_IN)
- Reg 193[0] (EN_ANA_CLKIN)

Master BCK & WS

- Reg 8
- Reg 7[7:5] MASTER_WS_SCALE
- Reg 9[6:0] SELECT_I2S_TDM_NUM
- Reg 193[2:1] (SEL_SYSCLK_IN)
- Reg 193[0] (EN_ANA_CLKIN)

TDM Clock

- Reg 10[0] (ENABLE_TDM_CLK)

S/PDIF Clock

- Reg 5[2] (ENABLE_SPDIF_CLK)

ASP1 Clock

- Reg 35[0] (ENABLE_ASP1_CLK)
- Reg 35[5:1] (SELECT_ASP1_NUM)
- Reg 1
 - Dependent on channels required
- Reg 193[2:1] (SEL_SYSCLK_IN)
- Reg 193[0] (EN_ANA_CLKIN)

**ASP2 Clock**

- Reg 36[0] (ENABLE_ASP1_CLK)
- Reg 36[5:1] (SELECT_ASP2_NUM)
- Reg 1
 - Dependent on channels required
- Reg 193[2:1] (SEL_SYSCLK_IN)
- Reg 193[0] (EN_ANA_CLKIN)

I2S Decoder Clock

- Uses BCK / WS



I2S Master Clock Rate Configurations

WS can be scaled down further than shown via Register 7 [7:5] MASTER_WS_SCALE.

MCLK Frequency	WS [kHz]	BCK [MHz]	Bits	Channels	Register 2 [4:0] SELECT_ADC_NUM		Register 9 [6:0] SELECT_I2S_TDM_NUM		Register 11 [5] TDM_LENGTH	
					value	divider	value	divider	value	length
22.579 MHz	44.1	2.822	32	2	5'd3	4	7'd3	4	1'b0	32
	88.2	5.645		2	5'd1	2	7'd1	2	1'b0	32
	176.4	11.290		2	5'd0	1	7'd0	1	1'b0	32
	44.1	1.411	16	2	5'd3	4	7'd3	4	1'b1	16
	88.2	2.822		2	5'd1	2	7'd1	2	1'b1	16
	176.4	5.645		2	5'd0	1	7'd0	1	1'b1	16
24.576 MHz	48	3.072	32	2	5'd3	4	7'd3	4	1'b0	32
	96	6.144		2	5'd1	2	7'd1	2	1'b0	32
	192	12.288		2	5'd0	1	7'd0	1	1'b0	32
	48	1.536	16	2	5'd3	4	7'd3	4	1'b1	16
	96	3.072		2	5'd1	2	7'd1	2	1'b1	16
	192	6.144		2	5'd0	1	7'd0	1	1'b1	16
45.158 MHz	44.1	2.822	32	2	5'd7	8	7'd7	8	1'b0	32
	88.2	5.645		2	5'd3	4	7'd3	4	1'b0	32
	176.4	11.290		2	5'd1	2	7'd1	2	1'b0	32
	352.8	22.579		2	5'd0	1	7'd0	1	1'b0	32
	44.1	1.411	16	2	5'd7	8	7'd7	8	1'b1	16
	88.2	2.822		2	5'd3	4	7'd3	4	1'b1	16
	176.4	5.645		2	5'd1	2	7'd1	2	1'b1	16
	352.8	11.290		2	5'd0	1	7'd0	1	1'b1	16
49.152 MHz	48	3.072	32	2	5'd7	8	7'd7	8	1'b0	32
	96	6.144		2	5'd3	4	7'd3	4	1'b0	32
	192	12.288		2	5'd1	2	7'd1	2	1'b0	32
	384	24.576		2	5'd0	1	7'd0	1	1'b0	32
	48	1.536	16	2	5'd7	8	7'd7	8	1'b1	16
	96	3.072		2	5'd3	4	7'd3	4	1'b1	16
	192	6.144		2	5'd1	2	7'd1	2	1'b1	16
	384	12.288		2	5'd0	1	7'd0	1	1'b1	16

Table 6 - I2S Master Clock Rate Configurations



I2S Slave Clock Rate Configurations

MCLK Frequency	WS [kHz]	BCK	Channels	Register 2 [4:0] SELECT_ADC_NUM		Register 0 [3] ENABLE_2X_M ODE	
				value	divider	value	multiplier
22.579 MHz	44.1	512FS	2	7'd3	4	1'b0	1x
	88.2	256FS	2	7'd1	2	1'b0	1x
	176.4	128FS	2	7'd0	1	1'b0	1x
	352.8	64FS	2	7'd0	1	1'b1	2x
24.576 MHz	48	512FS	2	7'd3	4	1'b0	1x
	96	256FS	2	7'd1	2	1'b0	1x
	192	128FS	2	7'd0	1	1'b0	1x
	384	64FS	2	7'd0	1	1'b1	2x
45.158 MHz	44.1	1024FS	2	7'd7	8	1'b0	1x
	88.2	512FS	2	7'd3	4	1'b0	1x
	176.4	256FS	2	7'd1	2	1'b0	1x
	352.8	128FS	2	7'd0	1	1'b0	1x
49.152 MHz	48	1024FS	2	7'd7	8	1'b0	1x
	96	512FS	2	7'd3	4	1'b0	1x
	192	256FS	2	7'd1	2	1'b0	1x
	384	128FS	2	7'd0	1	1'b0	1x

Table 7 - I2S Slave Clock Rate Configurations



TDM Slave Clock Rate Configurations

All configurations are 32-bit.

When using left justified mode (Register 10) remember to enable Reg 33 – sync positive edge of frame to correct for phase differences.

MCLK Frequency	WS [kHz]	BCK [MHz]	TDM Mode	Channels	Register 2 [4:0] SELECT_ADC_NUM	
					value	divider
22.579 MHz	44.1	5.645	TDM 128	4	5'd3	4
	88.2	11.290		4	5'd1	2
	176.4	22.579		4	5'd0	1
	44.1	11.290	TDM 256	8	5'd3	4
	88.2	22.579		8	5'd1	2
	44.1	22.579	TDM 512	16	5'd3	4
24.576 MHz	48	6.144	TDM 128	4	5'd3	4
	96	12.288		4	5'd1	2
	192	24.576		4	5'd0	1
	48	12.288	TDM 256	8	5'd3	4
	96	24.576		8	5'd1	2
	48	24.576	TDM 512	16	5'd3	4
45.158 MHz	44.1	5.645	TDM 128	4	5'd7	8
	88.2	11.290		4	5'd3	4
	176.4	22.579		4	5'd1	2
	44.1	11.290	TDM 256	8	5'd7	8
	88.2	22.579		8	5'd3	4
	44.1	22.579	TDM 512	16	5'd7	8
49.152 MHz	48	6.144	TDM 128	4	5'd7	8
	96	12.288		4	5'd3	4
	192	24.576		4	5'd1	2
	48	12.288	TDM 256	8	5'd7	8
	96	24.576		8	5'd3	4
	48	24.576	TDM 512	16	5'd7	8

Table 8 - TDM Slave Clock Rate Configurations



TDM Master Clock Rate Configurations

When using left justified mode (Register 10) remember to enable Reg 33 – sync positive edge of frame to correct for phase differences.

MCLK Frequency	WS [kHz]	BCK [MHz]	TDM Mode	Channels	Register 2 [4:0] SELECT_ADC_NUM		Register 9 [6:0] SELECT_I2S_TDM_NUM		Register 7 [7:5] MASTER_WS_SCALE		Register 8 [7] MASTER_BCK_DIV1	
					value	divider	value	divider	value	divider	value	divider
22.579 MHz	44.1	5.645	TDM 128	4	5'd3	4	7'd1	2	3'd1	2	1'b0	2
	88.2	11.290		4	5'd1	2	7'd0	1	3'd1	2	1'b0	2
	176.4	22.579		4	5'd0	1	7'd0	1	3'd0	1	1'b1	1
	44.1	11.290	TDM 256	8	5'd3	4	7'd0	1	3'd2	4	1'b0	2
	88.2	22.579		8	5'd1	2	7'd0	1	3'd1	2	1'b1	1
	44.1	22.579	TDM 512	16	5'd3	4	7'd0	1	3'd2	4	1'b1	1
24.576 MHz	48	6.144	TDM 128	4	5'd3	4	7'd1	2	3'd1	2	1'b0	2
	96	12.288		4	5'd1	2	7'd0	1	3'd1	2	1'b0	2
	192	24.576		4	5'd0	1	7'd0	1	3'd0	1	1'b1	1
	48	12.288	TDM 256	8	5'd3	4	7'd0	1	3'd2	4	1'b0	2
	96	24.576		8	5'd1	2	7'd0	1	3'd1	2	1'b1	1
	48	24.576	TDM 512	16	5'd3	4	7'd0	1	3'd2	4	1'b1	1
45.158 MHz	44.1	5.645	TDM 128	4	5'd7	8	7'd3	4	3'd1	2	1'b0	2
	88.2	11.290		4	5'd3	4	7'd1	2	3'd1	2	1'b0	2
	176.4	22.579		4	5'd1	2	7'd0	1	3'd1	2	1'b0	2
	44.1	11.290	TDM 256	8	5'd7	8	7'd1	2	3'd2	4	1'b0	2
	88.2	22.579		8	5'd3	4	7'd0	1	3'd2	4	1'b0	2
	44.1	22.579	TDM 512	16	5'd7	8	7'd0	1	3'd3	8	1'b0	2
49.152 MHz	48	6.144	TDM 128	4	5'd7	8	7'd3	4	3'd1	2	1'b0	2
	96	12.288		4	5'd3	4	7'd1	2	3'd1	2	1'b0	2
	192	24.576		4	5'd1	2	7'd0	1	3'd1	2	1'b0	2
	48	12.288	TDM 256	8	5'd7	8	7'd1	2	3'd2	4	1'b0	2
	96	24.576		8	5'd3	4	7'd0	1	3'd2	4	1'b0	2
	48	24.576	TDM 512	16	5'd7	8	7'd0	1	3'd3	8	1'b0	2

Table 9 - TDM Master Clock Rate Configurations



DSD Master Clock Rate Configurations

MCLK Frequency	BCK [MHz]	FS [kHz]	DSD Mode	Register 7 [3:0] SELECT_DSD_NUM		Register 7 [4] DSD_CLK_DIV 2		Reg 2 [4:0] SELECT_ADC_NUM	
				value	divider	value	divider	value	divider
22.579 MHz	2.822	44.1	DSD 64	5'd3	4	1'b1	2	5'd7	8
	5.645	44.1	DSD 128	5'd1	2	1'b1	2	5'd7	8
	11.290	44.1	DSD 256	5'd0	1	1'b1	2	5'd7	8
45.158 MHz	2.822	44.1	DSD 64	5'd7	8	1'b1	2	5'd7	8
	5.645	44.1	DSD 128	5'd3	4	1'b1	2	5'd7	8
	11.290	44.1	DSD 256	5'd1	2	1'b1	2	5'd7	8
	22.579	44.1	DSD 512	5'd0	1	1'b1	2	5'd7	8

Table 10 - DSD Master Clock Rate Configurations



Digital Audio Output Port

Pins are configured in Master (AUX Output) or Slave (Aux Input) modes through GPIO Configurations.

PCM Pin Connections

See Audio Interface Timing (I2S) for timing criteria. Can select GPIO 4,5,6 for the datapath.

Pin Name	Function	Description
GPIO1	I2S BCLK	I2S clock (Master or Slave)
GPIO2	I2S WS	I2S WS (Master or Slave)
GPIO3	I2S DATA	I2S DATA out (selectable for 2 channels)

Table 11 - PCM Pin Connections

TDM Pin Connections

See Registers 7-15 for configuration. Can select GPIO 4-6 for the datapath.

Pin Name	Function	Description
GPIO1	TDM BCK	TDM clock (Master or Slave)
GPIO2	TDM WS	TDM WS (Master or Slave)
GPIO3	TDM DATA	TDM DATA out (default)

Table 12 - TDM Pin Connections

DSD Pin Connections

DSD requires 1 pin per ADC channel, any channel can be mapped to any of the GPIOs (GPIO3-6). See registers 6,7,19 for configuration

Pin Name	Function	Description
GPIO1	DSD Clock	DSD Bit Clock (Master or Slave)
GPIO3	DSD DATA out	DSD data mapped to selected channel (Channel 1 default)
GPIO4	DSD DATA out	DSD data mapped to selected channel (Channel 2 default)

Table 13 - DSD Pin Connections

S/PDIF Pin Connections

S/PDIF Output is provided on GPIOs. Use GPIOx_CFG for S/PDIF output.

Pin Name	Description
GPIOx	GPIOx_CFG setting for GPIO of 4'd8 (S/PDIF output)

Table 14 - S/PDIF Pin Connections



RAW Pin Connections

RAW connections are configured by Registers 5,16,17. GPIOs need to be configured as well through registers 74-77.

RAW data mode requires 8 GPIOs.

Pin Name	Function	Description
GPIO1	RAW Data Clock Output	Clock output in RAW mode
GPIO2	RAW Data [0] Output	Raw data bit 0
GPIO3	RAW Data [1] Output	Raw data bit 1
GPIO4	RAW Data [2] Output	Raw data bit 2
GPIO5	RAW Data [3] Output	Raw data bit 3
GPIO6	RAW Data [4] Output	Raw data bit 4
GPIO7	RAW Data [5] Output	Raw data bit 5
GPIO8	RAW Data [6] Output	Raw data bit 6

Table 15 - RAW Pin Connections

Digital Audio Input Port

PCM Pin Connections

See I2S decoder and Programmable Delay. Registers 59-62 for configuration, GPIOs need to be configured as well through registers 74 & 76

Pin Name	Function	Description
GPIO1	I2S BCLK	I2S clock for I2S decoder
GPIO2	I2S WS	I2S WS for I2S decoder
GPIO5	I2S DATA	I2S DATA for I2S decoder

Table 16 - PCM Pin Connections



PCM Filter Impulse Response

The following impulse responses were obtained from software simulations of these filters. Simulation sample rate is 44.1kHz.

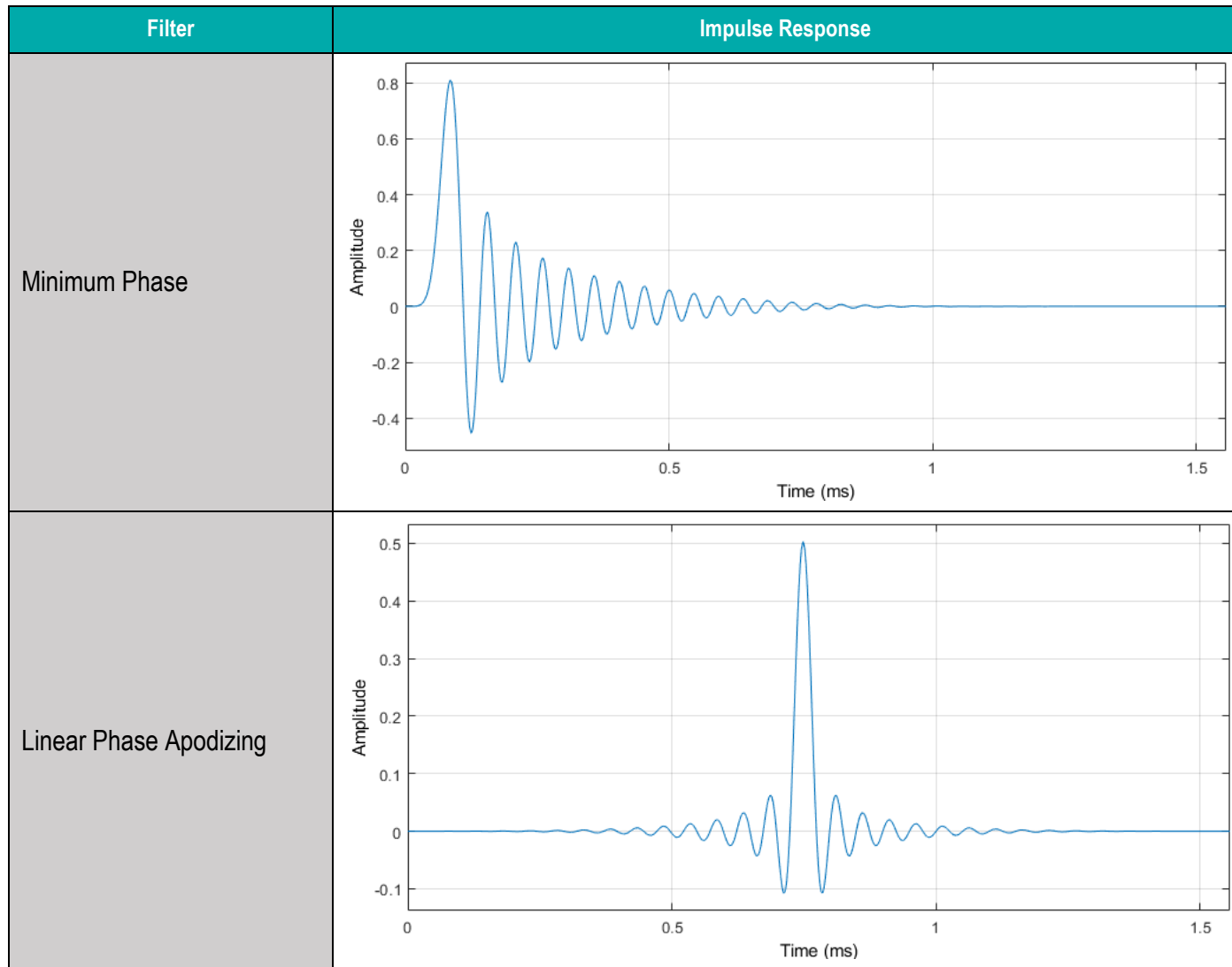

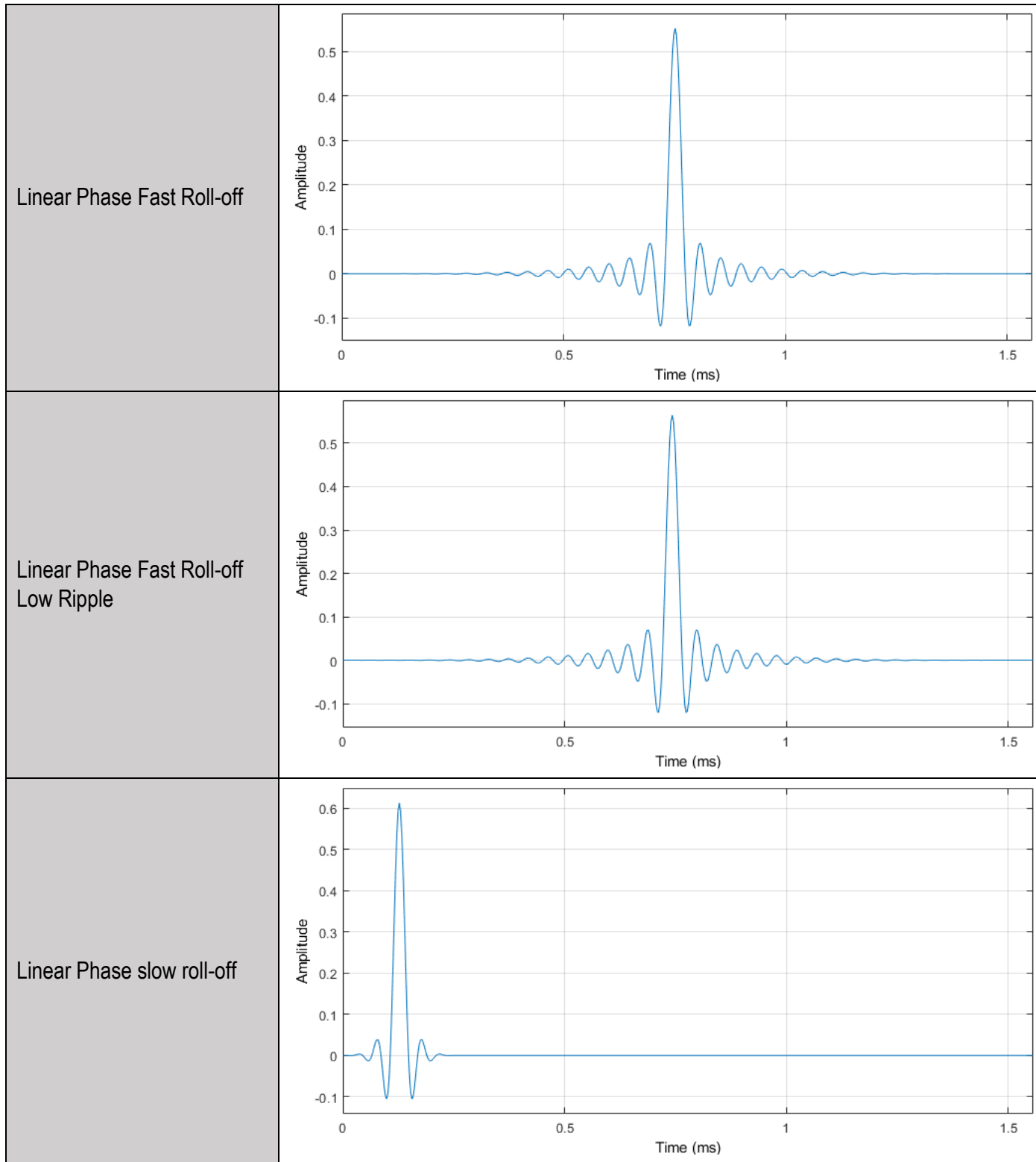



<p>Minimum phase fast roll-off</p>	
<p>Minimum phase slow roll-off</p>	
<p>Minimum phase slow roll-off low dispersion</p>	

Table 17 - PCM Filter Impulse Response



Absolute Maximum Ratings

PARAMETER	RATING
Positive Supply Voltage <ul style="list-style-type: none"> • AVCC_R/AVCC_L • AVCC • AVDD • DVDD 	<ul style="list-style-type: none"> • +4.75V with respect to Ground • +4.75V with respect to Ground • +3.7V with respect to Ground • +1.4V with respect to Ground
Storage temperature	-65°C to +150°C
Operating Junction Temperature	+125°C
Voltage range for digital input pins	-0.3V to AVDD (nom) + 0.3V
ESD Protection	
Human Body Model (HBM)	2kV
Charge Device Model (CDM)	500V

Table 18 - Absolute Maximum Ratings

WARNING: Stresses beyond those listed under here may cause permanent damage to the device. These are stress ratings only and functional operation of the device at these or any other conditions beyond those indicated under Recommended Operating Conditions is not implied.

WARNING: Electrostatic Discharge (ESD) can damage this device. Proper procedures must be followed to avoid ESD when handling this device.

IO Electrical Characteristics

PARAMETER	SYMBOL	MINIMUM	MAXIMUM	UNIT	COMMENTS
High-level input voltage	VIH	$(AVDD / 2) + 0.4$		V	
Low-level input voltage	VIL		0.4	V	
High-level output voltage	VOH	$AVDD - 0.2$		V	$IOH = ((AVDD / 2) + 1.4) \text{ mA}$
Low-level output voltage	VOL		0.2	V	$IOL = ((AVDD / 2) + 1.7) \text{ mA}$

Table 19 - IO Electrical Characteristics



Recommended Operating Conditions

There are the recommended operating conditions for the ES9822 PRO.

PARAMETER	SYMBOL	CONDITIONS
Operating temperature	T _A	-20°C to +85°C
AVCC		4.5V
AVDD		3.3V
AVCC_L		4.5V
AVCC_R		4.5V
VREF_L		Internal
VREF_R		Internal
DVDD		Internal

Table 20 - Recommended Operating Conditions

The minimum acceptable MCLK is 22MHz. Below this frequency, the device will not function.



Recommended Power up/down Sequences

The recommended power up/down sequences are show in the following diagram. All supplies and MCLK should be stable before CHIP_EN goes high.

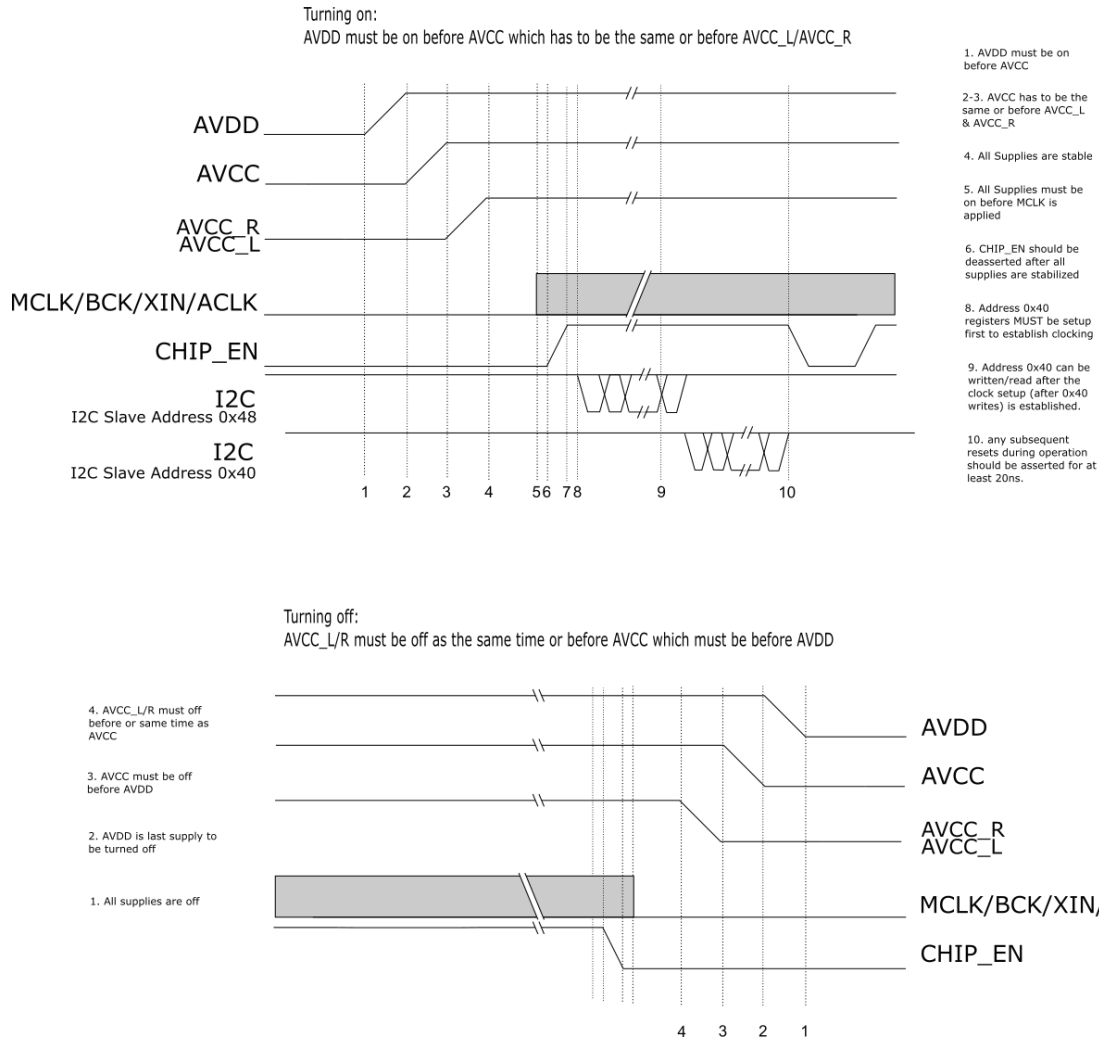

Figure 5 - Recommended Power up/down Sequences



Power Consumption

Test Conditions (unless otherwise noted)

$T_A = 25^\circ\text{C}$, $AVCC = AVCCL = AVCCR = +4.5\text{V}$, $AVDD = +3.3\text{V}$, $f_s = 48\text{kHz}$, $MCLK = 49.152\text{MHz}$, I2S output, with -1dBFS input signal

MCLK of 49.152Mhz is good for all sample rates

Parameter	Min	Typ	Max	Unit
Supply Current during 48kHz 2ch mode				
AVCC		26.5		mA
AVDD		15.2		mA
Standby				
AVCC		3		uA
AVDD		0.02		uA

Table 21 - 49.152Mhz MCLK Power Consumption

Test Conditions (unless otherwise noted)

$T_A = 25^\circ\text{C}$, $AVCC = AVCCL = AVCCR = +4.5\text{V}$, $AVDD = +3.3\text{V}$, $f_s = 48\text{kHz}$, $MCLK = 24.576\text{MHz}$, I2S output, with -1dBFS input signal

MCLK of 24.576Mhz is good for sample rates up to 192kHz

Parameter	Min	Typ	Max	Unit
Supply Current during 48kHz 2ch mode				
AVCC		26.4		mA
AVDD		12.9		mA
Standby				
AVCC		3		uA
AVDD		0.02		uA

Table 22 - 24.576MHz MCLK Power Consumption



Performance

Test Conditions (unless otherwise noted)

T_A = 25°C, AVCC = AVCC_L = AVCC_R = +4.5V, AVDD = +3.3V, f_s = 48kHz, MCLK = 49.152MHz, I2S output

Parameter			Min	Typ	Max	Unit
Resolution				32		Bit
0dBFS Input Voltage				3.2		V _{rms}
THD+N Ratio @ f _s =48kHz, BW=20Hz-20kHz	2 ch mode	-1dBFS		-117	-114	dB
	1 ch mode	-1dBFS		-118		dB
THD+N Ratio @ f _s =96kHz, BW=20Hz-40kHz	2 ch mode	-1dBFS		-115		dB
	1 ch mode	-1dBFS		-118		dB
THD+N Ratio @ f _s =192kHz, BW=20Hz-80kHz	2 ch mode	-1dBFS		-113		dB
	1 ch mode	-1dBFS		-116		dB
DNR A-wt	2ch mode	-60dBFS	122	125		dB
	1ch mode	-60dBFS	125	128		dB
Interchannel Gain Mismatch				±0.05	±0.4	dB
Input DC Common Mode				AVCC_L/2 AVCC_R/2		V
Input Impedance				430±14%		Ω
Cin (Input Capacitance)				~10		pF

Table 23 - Performance



Register Overview

The registers for the ES9822 PRO can be accessed either using an I²C or SPI interface.

The MODE pin (pin 3) determines which interface will be used:

- MODE = 1'b0
 - I²C interface (pull ups on SCL & SDA required)
 - Pin 25 SDA
 - Pin 26 SCL
 - Pin 27 ADDR1
 - Pin 28 ADDR2
 - ADDR1 & ADDR2 determine the I²C address
 - I²C Slave Address = [5'b01000,ADDR2,ADDR1,R/W]
 - Possible addresses are 0x40,0x42,0x44,0x46 for I²C Slave Address
 - I²C Synchronous Slave Address = [5'b01001,ADDR2,ADDR1,R/W]
 - Possible addresses are 0x48,0x4A,0x4C,0x4E for I²C Synchronous Slave Address
- MODE = 1'b1
 - SPI interface
 - The SPI Slave interface can be accessed using the Pins 25-28
 - Pin 25 MOSI
 - Pin 26 SCLK
 - Pin 27 SS
 - Pin 28 MISO

I ² C Slave Address	I ² C Synchronous Slave Address	ADDR2	ADDR1
0x40	0x48	L	L
0x42	0x4A	L	H
0x44	0x4C	H	L
0x46	0x4E	H	H

Table 24 - I²C Addresses



I²C Slave Interface (Device Address 0x40,0x42,0x44,0x46)

This interface contains Read/Write and Read-only registers. A system clock must be present.

Multi-byte registers must be written from LSB to MSB. Data is latched when MSB is written.

Multi-byte registers must be read from LSB to MSB. Data is latched when LSB is read.

MSB is always stored in the highest register address.

Read/Write Register Addresses

Registers 0–179 (0x00 – 0xB3) are read/write registers

Read-only Register Addresses

Registers 224 – 253 (0xE0 – 0xFD) are read only registers.

I²C Synchronous Slave Interface (Device Address 0x48,0x4A,0x4C,0x4E)

This interface contains Write-only registers. These registers can be written even when there is no system clock present.

When the device is inactive, all peripherals are automatically disabled and all clocks are stopped. An interrupt or a reset can wake the ES9822 PRO

Write-only Register Addresses

Registers 192 – 194 (0xC0 – 0xC2) are write only registers.

Multi-Byte Registers

Multi-byte registers must be written from LSB to MSB. Data is latched when MSB is written.

MSB is always stored in the highest register address.



I²C Slave/Synchronous Slave Interface Timing

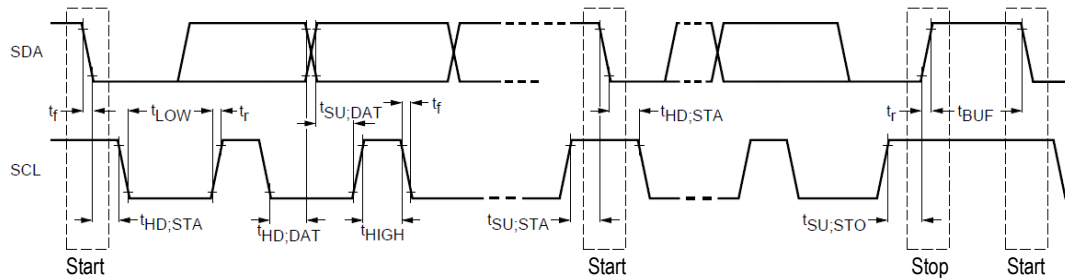

Figure 6 - I2C Slave Control Interface Timing Diagram

Parameter	Symbol	CLK Constraint	Standard-Mode		Fast-Mode		Unit
			MIN	MAX	MIN	MAX	
SCL Clock Frequency	f_{SCL}	$< CLK/20$	0	100	0	400	kHz
START condition hold time	$t_{HD,STA}$		4.0	-	0.6	-	μs
LOW period of SCL	t_{LOW}	$>10/CLK$	4.7	-	1.3	-	μs
HIGH period of SCL ($>10/CLK$)	t_{HIGH}	$>10/CLK$	4.0	-	0.6	-	μs
START condition setup time (repeat)	$t_{SU,STA}$		4.7	-	0.6	-	μs
SDA hold time from SCL falling - All except NACK read - NACK read only	$t_{HD,DAT}$		0 2/CLK	-	0 2/CLK	-	μs s
SDA setup time from SCL rising	$t_{SU,DAT}$		250	-	100	-	ns
Rise time of SDA and SCL	t_r		-	1000		300	ns
Fall time of SDA and SCL	t_f		-	300		300	ns
STOP condition setup time	$t_{SU,STO}$		4	-	0.6	-	μs
Bus free time between transmissions	t_{BUF}		4.7	-	1.3	-	μs
Capacitive load for each bus line	C_b		-	400	-	400	pF

Table 25 - I2C Slave Control Interface Timing Definitions



SPI Slave Interface

The SPI slave interface is used when the MODE pin (pin 3) is pulled high.

- The SPI Slave interface can be accessed using the Pins 25-28
 - Pin 25 MOSI
 - Pin 26 SCLK
 - Pin 27 SS
 - Pin 28 MISO

The 4-wire SPI data format is: Command (1 byte) + Address (1 byte) + Data

SPI commands:

- 0x01: Read
- 0x03: Write
- 0x07: Write-only Register Addresses 192-194 (0xC0 – 0xC2)

Single byte Write

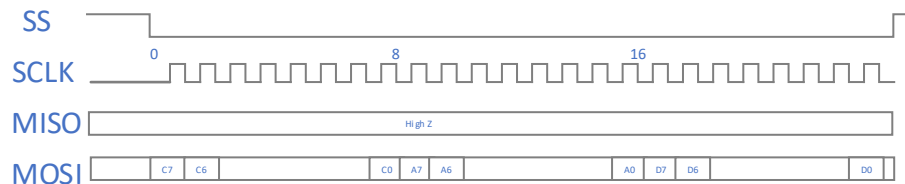

Single byte Read

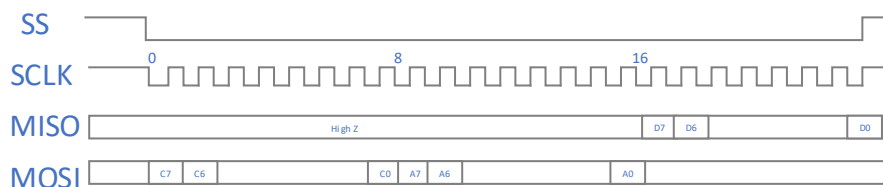

Multiple byte Read

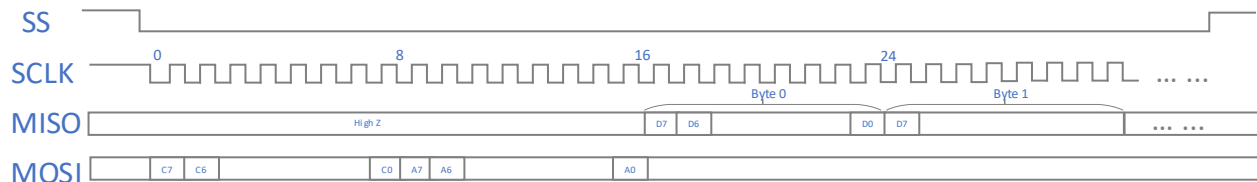

Figure 7 - SPI Timing Diagrams



Register Map

Addr (Hex)	Addr (Dec)	Register	7	6	5	4	3	2	1	0	
0x0	0	SYS CONFIG	SOFT_RESET	OUTPUT_SEL		RESERVED	ENABLE_2X_MODE	RESERVED	MONO_MODE	RESERVED	
0x1	1	ADC CLOCK CONFIG1	ENABLE_DATA_IN_CH2B	ENABLE_DATA_IN_CH1B	ENABLE_DATA_IN_CH2A	ENABLE_DATA_IN_CH1A	ENABLE_ADC_CH2B	ENABLE_ADC_CH1B	ENABLE_ADC_CH2A	ENABLE_ADC_CH1A	
0x2	2	ADC CLOCK CONFIG2	RESERVED		SELECT_ADC_HALF	SELECT_ADC_NUM					
0x3	3	ADC CLOCK CONFIG3	OUTPUT2_SEL		FORCE_OUTPUT2	INVERT_FIR_T_CLK_SAMPLE2	SELECT_IADC_HALF	SELECT_IADC_NUM			
0x4	4	ADC CLOCK CONFIG4	FORCE_PHASE_CLK_IADC	PHASE_CLK_IADC			RESERVED		INVERT_SAMPLE_CLOCK_CH2	INVERT_SAMPLE_LOCK_CH1	
0x5	5	RAW DATA AND SPDIF CONFIG	SELECT_RAW_DATA_NUM		RAW_DATA_CLK_DIV2	RAW_DATA_DR	ENABLE_RAW_DATA_CLK	ENABLE_SPDIF_CLK	RESERVED		
0x6	6	DSD CONFIG	RESERVED		DSD_DDR	DSD_MASTER_MODE	RESERVED		ENABLE_DSD_CLK_CH2	ENABLE_DSD_CLK_CH1	
0x7	7	DSD AND I2S/TDM MASTER CLK CONFIG	MASTER_WS_SCALE			DSD_CLK_DIV2	SELECT_DSD_NUM				
0x8	8	I2S/TDM MASTER MODE CONFIG	MASTER_BCK_DIV1	MASTER_WS_IDL	MASTER_FRAME_LENGTH		MASTER_WS_PULSE_MODE	MASTER_BCK_INVERT	MASTER_WS_INVERT	MASTER_MODE_ENABLE	
0x9	9	I2S/TDM MASTER CLK CONFIG	SELECT_I2S_TDM_HALF	SELECT_I2S_TDM_NUM							
0xA	10	TDM CONFIG1	TDM_BIT_DELAY					TDM_VALID_EDGE	TDM_LJ	ENABLE_TDM_CLK	
0xB	11	TDM CONFIG2	TDM_GPIO456	TDM_CASCADE	TDM_LENGTH	TDM_CH_NUM					
0xC	12	TDM SLOT CONFIG CH1	RESERVED			TDM_SLOT_SEL_CH1					
0xD	13	TDM SLOT CONFIG CH2	RESERVED			TDM_SLOT_SEL_CH2					
0xE	14	RESERVED	RESERVED								
0xF	15	RESERVED	RESERVED								
0x10	16	RESERVED	RESERVED								
0x11	17	RAW DATA MAPPING	RESERVED				RAW_DATA_MAPPING_CH2		RAW_DATA_MAPPING_CH1		
0x12	18	PCM DATA OUTPUT MAPPING	RESERVED				OUTPUT_MAPPING_CH2		OUTPUT_MAPPING_CH1		
0x13	19	DSD DATA OUTPUT MAPPING	RESERVED				DSD_MAPPING_CH2		DSD_MAPPING_CH1		
0x14	20	TPDF DITHER LEVEL	RESERVED			DITHER_SCALE					
0x15	21	DITHER MASK	DITHER_MASK								
0x16	22	DITHER MASK	DITHER_MASK								
0x17	23	FS GEN PHASE CONTROL	DSD_SYNC_TO_1_FS	FS_PHASE							
0x18-0x1A	24-26	RESERVED	RESERVED								
0x1B	27	INTERRUPT	RESERVED		INTERRUPT_CLEAR_CH2_CLIP_DETECTION	INTERRUPT_CLEAR_CH1_CLIP_DETECTION	RESERVED		INTERRUPT_MASK_CH2_CLIP_DETECTION	INTERRUPT_MASK_CH1_CLIP_DETECTION	
0x20-0x1C	32-28	SPDIF CONFIG	SPDIF_CS								
0x21	33	DSD DITHER SCALE AND SYNC CONTROL	SYNC_POSEDGE_FRAME	DISABLE_SYNC_REF	FORCE_FIR_SYNC	DSD_DITHER_SCALE					
0x22	34	SYNC CONTROL	AUTO_ADC_CLKDIV_SYNC	AUTO_CLK_IADC_PHASE_SYNC	AUTO_DSD_PHASE_SYNC	AUTO_WS_PHASE_SYNC	AUTO_ICG_ENABLE_SYNC	AUTO_ICG_SYNC	AUTO_FIR_SYNC	AUTO_FS_SYNC	
0x23	35	ASP1 CONFIG	RESERVED		SELECT_ASP1_NUM					ENABLE_ASP1_CLK	

ES9822 PRO Product Datasheet



0x24	36	ASP2 CONFIG	RESERVED		SELECT_ASP2_NUM					ENABLE_ASP2_CLK	
0x25	37	ASP ENABLE AND PROGRAMMING CONTROL	ASP2_COEFF_WE	ASP1_COEFF_WE	ASP2_PROGRAM_WE	ASP1_PROGR_AM_WE	ASP2_PROGRA_M_EN	ASP1_PROGRAM_EN	ENABLE_ASP2	ENABLE_ASP1	
0x26	38	ASP PROGRAM ADDR	ASP_PROGRAM_ADDR								
0x27	39	ASP PROGRAM ADDR	ASP_PROGRAM_ADDR								
0x28	40	ASP PROGRAM	ASP_PROGRAM_IN								
0x29	41	ASP PROGRAM	RESERVED		ASP_PROGRAM_IN						
0x2A	42	ASP COEFF ADDR	RESERVED		ASP_COEFF_ADDR						
0x2B	43	ASP COEFF	ASP_COEFF_MSB								
0x2C	44	ASP COEFF	ASP_COEFF_MSB								
0x2D	45	ASP COEFF	ASP_COEFF_MSB								
0x2E	46	ASP COEFF	ASP_COEFF_MSB								
0x2F	47	ASP COEFF	ASP_COEFF_LSB								
0x30	48	ASP COEFF	ASP_COEFF_LSB								
0x31	49	ASP COEFF	ASP_COEFF_LSB								
0x32	50	ASP COEFF	ASP_COEFF_LSB								
0x33	51	ASP1 CH1 STEP SIZE	ASP1_CH1_STEP_SIZE								
0x34	52	ASP1 CH2 STEP SIZE	ASP1_CH2_STEP_SIZE								
0x35	53	ASP2 CH1 STEP SIZE	ASP2_CH1_STEP_SIZE								
0x36	54	ASP2 CH2 STEP SIZE	ASP2_CH2_STEP_SIZE								
0x37	55	ASP1 CUSTOM ADDR	RESERVED		ASP1_CUSTOM_ADDR						
0x38	56	ASP1 CUSTOM ADDR2	RESERVED		ASP1_CUSTOM_ADDR2						
0x39	57	ASP2 CUSTOM ADDR	RESERVED		ASP2_CUSTOM_ADDR						
0x3A	58	ASP2 CUSTOM ADDR2	RESERVED		ASP2_CUSTOM_ADDR2						
0x3B	59	I2S DECODER CONFIG	I2S_DECODER_BIT_START								
0x3C	60	I2S DECODER CONFIG	I2S_DECODER_BIT_START	I2S_DECODER_WORD_SEL	I2S_DECODER_POSEDGE_FRAME	ENABLE_I2S_DECORDER	I2S_DECODER_BIT_START				
0x3D	61	DELAY LINE CONFIG	PROG_DELAY_LINE								
0x3E	62	DELAY LINE CONFIG	RESERVED							ENABLE_CLK_DL	PROG_DELAY_LINE
0x3F	63	ADC CH1A CONFIG 1	ADC_INT_SEL_CH1A			ADC_EN_FB_C_H1A	RESERVED	ADC_EN_INT_C_H1A	ADC_EN_CH1A		
0x40	64	ADC CH1A CONFIG 2	ADC_COMP_SEL_CH1A		ADC_SUM_SEL_CH1A		RESERVED				
0x41	65	ADC CH2A CONFIG 1	ADC_INT_SEL_CH2A			ADC_EN_FB_C_H2A	RESERVED	ADC_EN_INT_C_H2A	ADC_EN_CH2A		
0x42	66	ADC CH2A CONFIG 2	ADC_COMP_SEL_CH2A		ADC_SUM_SEL_CH2A		RESERVED				
0x43	67	ADC CH1B CONFIG 1	ADC_INT_SEL_CH1B			ADC_EN_FB_C_H1B	RESERVED	ADC_EN_INT_C_H1B	ADC_EN_CH1B		
0x44	68	ADC CH1B CONFIG 2	ADC_COMP_SEL_CH1B		ADC_SUM_SEL_CH1B		RESERVED				
0x45	69	ADC CH2B CONFIG 1	ADC_INT_SEL_CH2B			ADC_EN_FB_C_H2B	RESERVED	ADC_EN_INT_C_H2B	ADC_EN_CH2B		
0x46	70	ADC CH2B CONFIG 2	ADC_COMP_SEL_CH2B		ADC_SUM_SEL_CH2B		RESERVED				
0x47	71	ADC COMMON MODE CONFIG	ADC_CM_SEL_CH2B		ADC_CM_SEL_CH1B		ADC_CM_SEL_CH2A		ADC_CM_SEL_CH1A		
0x48	72	RESERVED	RESERVED								
0x49	73	VREF CONFIG	RESERVED		AREF_PDB	PDB_AREGR	PDB_AREGL	FC_LN	ENFCB_R	ENFCB_L	
0x4A	74	GPIO1/2 CONFIG	GPIO2_CFG				GPIO1_CFG				
0x4B	75	GPIO3/4 CONFIG	GPIO4_CFG				GPIO3_CFG				



ES9822 PRO Product Datasheet

0x4C	76	GPIO5/6 CONFIG	GPIO6_CFG				GPIO5_CFG				
0x4D	77	GPIO7/8 CONFIG	GPIO8_CFG				GPIO7_CFG				
0x4E	78	GPIO9/10 CONFIG	GPIO10_CFG				GPIO9_CFG				
0x4F	79	GPIO11 CONFIG	RESERVED				GPIO11_CFG				
0x50-0x51	80-81	RESERVED	RESERVED								
0x52	82	INVERT GPIO	INVERT_GPIO8	INVERT_GPIO7	INVERT_GPIO6	INVERT_GPIO5	INVERT_GPIO4	INVERT_GPIO3	INVERT_GPIO2	INVERT_GPIO1	
0x53	83	INVERT GPIO	RESERVED					INVERT_GPIO11	INVERT_GPIO10	INVERT_GPIO9	
0x54	84	GPIO WEAK ENABLE	GPIO8_WK_EN	GPIO7_WK_EN	GPIO6_WK_EN	GPIO5_WK_EN	GPIO4_WK_EN	GPIO3_WK_EN	GPIO2_WK_EN	GPIO1_WK_EN	
0x55	85	GPIO WEAK ENABLE	RESERVED					GPIO11_WK_EN	GPIO10_WK_EN	GPIO9_WK_EN	
0x56	86	GPIO IE	GPIO8_IE	GPIO7_IE	GPIO6_IE	GPIO5_IE	GPIO4_IE	GPIO3_IE	GPIO2_IE	GPIO1_IE	
0x57	87	GPIO IE	RESERVED					GPIO11_IE	GPIO10_IE	GPIO9_IE	
0x58	88	GPIO OE	GPIO8_OE	GPIO7_OE	GPIO6_OE	GPIO5_OE	GPIO4_OE	GPIO3_OE	GPIO2_OE	GPIO1_OE	
0x59	89	GPIO OE	RESERVED					GPIO11_OE	GPIO10_OE	GPIO9_OE	
0x5A	90	GPIO READ	GPIO8_READ	GPIO7_READ	GPIO6_READ	GPIO5_READ	GPIO4_READ	GPIO3_READ	GPIO2_READ	GPIO1_READ	
0x5B	91	GPIO READ	RESERVED					GPIO11_READ	GPIO10_READ	GPIO9_READ	
0x5C	92	PWM1 COUNT	PWM1_COUNT								
0x5D	93	PWM1 FREQUENCY	PWM1_FREQ								
0x5E	94	PWM1 FREQUENCY	PWM1_FREQ								
0x5F	95	PWM2 COUNT	PWM2_COUNT								
0x60	96	PWM2 FREQUENCY	PWM2_FREQ								
0x61	97	PWM2 FREQUENCY	PWM2_FREQ								
0x62	98	PWM3 COUNT	PWM3_COUNT								
0x63	99	PWM3 FREQUENCY	PWM3_FREQ								
0x64	100	PWM3 FREQUENCY	PWM3_FREQ								
0x65	101	ADC CH1 DATAPATH CONTROL	ADC1_BYPASS_FIR2X	ADC1_BYPASS_FIR4X	RESERVED			ADC1_ENABLE_DC_BLOCKING	RESERVED	ADC1_NEG_SEL	
0x66	102	ADC CH1 THD COMP CONFIG	ADC1_CORRECTION_ADDR					ADC1_CORRECTION_WE	ADC1_ENABLE_THD_COMP		
0x67	103	ADC CH1 THD COMP DATA	ADC1_CORRECTION_DATA								
0x68	104	ADC CH1 THD COMP DATA	ADC1_CORRECTION_DATA								
0x69	105	ADC CH1 PEAK DETECTOR CONFIG	ADC1_LOCK_PEAK	ADC1_DECAY_RATE				RESERVED	ADC1_ENABLE_PEAK_DETECT		
0x6A	106	ADC CH1 PEAK DETECTOR LEVEL	ADC1_CLIP_LEVEL								
0x6B	107	ADC CH1 DC OFFSET	ADC1_DC_OFFSET								
0x6C	108	ADC CH1 DC OFFSET	ADC1_DC_OFFSET								
0x6D	109	ADC CH1 VOLUME	ADC1_VOLUME								
0x6E	110	ADC CH1 VOLUME	ADC1_VOLUME								
0x6F	111	ADC CH1 VOLUME RATE	ADC1_VOLUME_RATE								
0x70	112	ADC CH1 SCALE	RESERVED					ADC1_DATA_SCALE			
0x71	113	ADC CH1 PROG FILTER	RESERVED			ADC1_FILTER_SHAPE			ADC1_PROG_COEFF_WRITE_EN	ADC1_PROG_COEFF_EN	
0x72	114	ADC CH1 PROG FILTER COEFF ADDR	ADC1_PROG_COEFF_STAGE	ADC1_PROG_COEFF_ADDR							
0x73	115	ADC CH1 PROG FILTER COEFF	ADC1_PROG_COEFF_IN								

ES9822 PRO Product Datasheet



0x74	116	ADC CH1 PROG FILTER COEFF	ADC1_PROG_COEFF_IN							
0x75	117	ADC CH1 PROG FILTER COEFF	ADC1_PROG_COEFF_IN							
0x76	118	ADC CH2 DATAPATH CONTROL	ADC2_BYPASS_FIR2X	ADC2_BYPASS_FIR4X	RESERVED		ADC2_ENABLE_DDC_BLOCKING	RESERVED	ADC2_NEG_SEL	
0x77	119	ADC CH2 THD COMP CONFIG	ADC2_CORRECTION_ADDR					ADC2_CORRECTION_WE	ADC2_ENABLE_THD_COMP	
0x78	120	ADC CH2 THD COMP DATA	ADC2_CORRECTION_DATA							
0x79	121	ADC CH2 THD COMP DATA	ADC2_CORRECTION_DATA							
0x7A	122	ADC CH2 PEAK DETECTOR CONFIG	ADC2_LOCK_PEAK	ADC2_DECAY_RATE				RESERVED	ADC2_ENABLE_PEAK_DETECT	
0x7B	123	ADC CH2 PEAK DETECTOR LEVEL	ADC2_CLIP_LEVEL							
0x7C	124	ADC CH2 DC OFFSET	ADC2_DC_OFFSET							
0x7D	125	ADC CH2 DC OFFSET	ADC2_DC_OFFSET							
0x7E	126	ADC CH2 VOLUME	ADC2_VOLUME							
0x7F	127	ADC CH2 VOLUME	ADC2_VOLUME							
0x80	128	ADC CH2 VOLUME RATE	ADC2_VOLUME_RATE							
0x81	129	ADC CH2 SCALE	RESERVED					ADC2_DATA_SCALE		
0x82	130	ADC CH2 PROG FILTER	RESERVED			ADC2_FILTER_SHAPE		ADC2_PROG_COEFF_WRITE_EN	ADC2_PROG_COEFF_EN	
0x83	131	ADC CH2 PROG FILTER COEFF ADDR	ADC2_PROG_COEFF_STAGE	ADC2_PROG_COEFF_ADDR						
0x84	132	ADC CH2 PROG FILTER COEFF	ADC2_PROG_COEFF_IN							
0x85	133	ADC CH2 PROG FILTER COEFF	ADC2_PROG_COEFF_IN							
0x86	134	ADC CH2 PROG FILTER COEFF	ADC2_PROG_COEFF_IN							
0x87	135	ADC CH1B DATAPATH CONTROL	RESERVED						ADC1B_NEG_SEL	
0x88-0x97	136-151	RESERVED	RESERVED							
0x98	152	ADC CH2B DATAPATH CONTROL	RESERVED						ADC2B_NEG_SEL	
0xC0	192	SOFT RESET	AO_SOFT_RESET	RESERVED						
0xC1	193	CLK SELECT	RESERVED				SEL_SYSCLK_IN		EN_ANA_CLKIN	
0xC2	194	ADC CLOCK DIVIDE	RESERVED					SEL_CLK_DIV		
0xC3-CB	195-203	RESERVED	RESERVED							
0xE0	224	READ SYSTEM REGISTER 0	RESERVED			MODE	ADDR2	ADDR1	RESERVED	
0xE1	225	CHIP ID	CHIP_ID							
0xE2-0xE4	226-228	RESERVED	RESERVED							
0xE5	229	CLIP FLAG	RESERVED					CLIP_FLAG_CH2	CLIP_FLAG_CH1	
0xE6	230	RESERVED	RESERVED							
0xE7	231	READ SYSTEM REGISTER 5	ASP2_INIT_DONE	ASP1_INIT_DONE	RESERVED	TDM_VALID	RESERVED			
0xE8	232	GPIO READBACK REGISTERS	GPIO8_READBACK	GPIO7_READBACK	GPIO6_READBACK	GPIO5_READBACK	GPIO4_READBACK	GPIO3_READBACK	GPIO2_READBACK	GPIO1_READBACK
0xE9	233	GPIO READBACK REGISTERS	RESERVED				GPIO11_READBACK	GPIO10_READBACK	GPIO9_READBACK	



0xEA	234	PROG COEFF OUT	ADC1_PROG_COEFF_OUT
0xEB	235	PROG COEFF OUT	ADC1_PROG_COEFF_OUT
0xEC	236	PROG COEFF OUT	ADC1_PROG_COEFF_OUT
0xED	237	PEAK	ADC1_PEAK
0xEE	238	PEAK	ADC1_PEAK
0xEF	239	PROG COEFF OUT	ADC2_PROG_COEFF_OUT
0xF0	240	PROG COEFF OUT	ADC2_PROG_COEFF_OUT
0xF1	241	PROG COEFF OUT	ADC2_PROG_COEFF_OUT
0xF2	242	PEAK	ADC2_PEAK
0xF3	243	PEAK	ADC2_PEAK

Table 26 - Register Map



Register Listing

Some RESERVED registers do not default to 0x00 and should not be modified for normal operation. If the value of the reserved registers is changed from the default state, it will be noted.

System Registers

Register 0: SYS CONFIG

Bits	[7]	[6:5]	[4]	[3]	[2]	[1]	[0]
Default	1'b0	2'b00	1'b0	1'b0	1'b0	1'b0	1'b0

Bits	Mnemonic	Description
[7]	SOFT_RESET	Performs soft reset to digital <ul style="list-style-type: none"> 1'b0: Normal operation 1'b1: Reset digital
[6:5]	OUTPUT_SEL	Selects output data format. <ul style="list-style-type: none"> 2'd0: I2S output (default) 2'd1: SPDIF output 2'd2: TDM output 2'd3: DSD output
[4]	RESERVED	NA
[3]	ENABLE_2X_MODE	Enables 2x mode for 768k sample rate. <ul style="list-style-type: none"> 1'b0: 2x mode disabled (default) 1'b1: 2x mode enabled
[2]	RESERVED	NA
[1]	MONO_MODE	Enables mono mode. Both channels data are mixed into Ch1. For Ch1, mono mode has higher priority than two channel mode. <ul style="list-style-type: none"> 1'b0: Mono mode disabled (default) 1'b1: Mono mode enabled
[0]	RESERVED	NA



Register 1: ADC CLOCK CONFIG1

Bits	[7]	[6]	[5]	[4]	[3]	[2]	[1]	[0]
Default	1'b0	1'b0	1'b0	1'b0	1'b0	1'b0	1'b0	1'b0

Bits	Mnemonic	Description
[7]	ENABLE_DATA_IN_CH2B	Enables Ch2B data input clock (before decimation path) for data mixing. <ul style="list-style-type: none"> 1'b0: Clock disabled (default) 1'b1: Clock enabled
[6]	ENABLE_DATA_IN_CH1B	Enables Ch1B data input clock (before decimation path) for data mixing. <ul style="list-style-type: none"> 1'b0: Clock disabled (default) 1'b1: Clock enabled
[5]	ENABLE_DATA_IN_CH2A	Enables Ch2A data input clock (before decimation path) for data mixing. <ul style="list-style-type: none"> 1'b0: Clock disabled (default) 1'b1: Clock enabled
[4]	ENABLE_DATA_IN_CH1A	Enables Ch1A data input clock (before decimation path) for data mixing. <ul style="list-style-type: none"> 1'b0: Clock disabled (default) 1'b1: Clock enabled
[3]	ENABLE_ADC_CH2B	Enables ADC Ch2B decimation path clock. <ul style="list-style-type: none"> 1'b0: Clock disabled (default) 1'b1: Clock enabled
[2]	ENABLE_ADC_CH1B	Enables ADC Ch1B decimation path clock. <ul style="list-style-type: none"> 1'b0: Clock disabled (default) 1'b1: Clock enabled
[1]	ENABLE_ADC_CH2A	Enables ADC Ch2A decimation path clock. <ul style="list-style-type: none"> 1'b0: Clock disabled (default) 1'b1: Clock enabled
[0]	ENABLE_ADC_CH1A	Enables ADC Ch1A decimation path clock. <ul style="list-style-type: none"> 1'b0: Clock disabled (default) 1'b1: Clock enabled



Register 2: ADC CLOCK CONFIG2

Bits	[7:6]	[5]	[4:0]
Default	2'b00	1'b0	5'd3

Bits	Mnemonic	Description
[7:6]	RESERVED	NA
[5]	SELECT_ADC_HALF	<ul style="list-style-type: none"> 1'b0: Divide by SELECT_ADC_NUM + 1 (default) 1'b1: Divide by half of SELECT_ADC_NUM + 1 Note: Can only produce half of an odd number divide
[4:0]	SELECT_ADC_NUM	Whole number divide value + 1 for CLK_ADC (SYS_CLK/divide_value). <ul style="list-style-type: none"> 5'd0: Whole number divide value + 1 = 1 5'd1: Whole number divide value + 1 = 2 5'd31: Whole number divide value + 1 = 32



Register 3: ADC CLOCK CONFIG3

Bits	[7:6]	[5]	[4]	[3]	[2:0]
Default	2'd0	1'b0	1'b0	1'b0	3'd0

Bits	Mnemonic	Description
[7:6]	OUTPUT2_SEL	Selects DATA2 output (GPIO4) when "FORCE_OUTPUT2" is set. <ul style="list-style-type: none"> 2'd0 -> I2S (default) 2'd1 -> SPDIF 2'd2 -> TDM 2'd3 -> DSD
[5]	FORCE_OUTPUT2	Forces DATA2 output (GPIO4) to output from a different source, controlled by "OUTPUT2_SEL". <ul style="list-style-type: none"> 1'b0: Use "OUTPUT_SEL" (default) 1'b1: Use "OUTPUT2_SEL"
[4]	INVERT_FIRST_CLK_SAMPLE2	Firstly, use neg edge of CLK_SAMPLE2 to sample adc_data_r1. Only used when different CLK_SAMPLE1 edges are used for the 2ch to ensure phase alignment. <ul style="list-style-type: none"> 1'b0: Use pos edge of CLK_SAMPLE2 to sample adc_data_r1 (default) 1'b1: Use neg edge of CLK_SAMPLE2 to sample adc_data_r1
[3]	SELECT_IADC_HALF	<ul style="list-style-type: none"> 1'b0: Divide by SELECT_IADC_NUM + 1 (default) 1'b1: Divide by half of SELECT_IADC_NUM + 1 Note: Can only produce half of an odd number divide
[2:0]	SELECT_IADC_NUM	Whole number divide value + 1 for CLK_IADC (SYS_CLK/divide_value). <ul style="list-style-type: none"> 3'd0: Whole number divide value + 1 = 1 (default) 3'd1: Whole number divide value + 1 = 2 3'd7: Whole number divide value + 1 = 8



Register 4: ADC CLOCK CONFIG4

Bits	[7]	[6:4]	[3:2]	[1]	[0]
Default	1'b0	3'd0	2'b00	1'b0	1'b0

Bits	Mnemonic	Description
[7]	FORCE_PHASE_CLK_IADC	Sets phase of CLK_IADC by PHASE_CLK_IADC. <ul style="list-style-type: none"> 1'b0: Auto phase tuning if AUTO_CLK_IADC_PHASE_SYNC is set (default) 1'b1: Sets phase by PHASE_CLK_IADC
[6:4]	PHASE_CLK_IADC	Sets phase of CLK_IADC relative to SYS_CLK when FORCE_PHASE_CLK_IADC is set. For 48M SYS_CLK and 24M CLK_IADC only. <ul style="list-style-type: none"> 3'd0: Phase 0 (default) 3'd1: Phase 1 others: Reserved
[3:2]	RESERVED	NA
[1]	INVERT_SAMPLE_CLOCK_CH2	Inverts ADC Ch2 data sampling clock. <ul style="list-style-type: none"> 1'b0: Not inverted (default) 1'b1: Inverted
[0]	INVERT_SAMPLE_CLOCK_CH1	Inverts ADC Ch1 data sampling clock. <ul style="list-style-type: none"> 1'b0: Not inverted (default) 1'b1: Inverted



Register 5: RAW DATA AND SPDIF CONFIG

Bits	[7:6]	[5]	[4]	[3]	[2]	[1:0]
Default	2'd0	1'b0	1'b0	1'b0	1'b0	2'd0

Bits	Mnemonic	Description
[7:6]	SELECT_RAW_DATA_NUM	Whole number divide value + 1 for raw data clock (SYS_CLK/divide_value). When SELECT_RAW_DATA_NUM is larger than 0, the divided clock is not a 50% duty cycle clock. <ul style="list-style-type: none"> • 2'd0: Whole number divide value + 1 = 1 (default) • 2'd1: Whole number divide value + 1 = 2 • 2'd2: Whole number divide value + 1 = 3 • 2'd3: Whole number divide value + 1 = 4
[5]	RAW_DATA_CLK_DIV2	Further divides the raw data clock by 2 (after divided by SELECT_RAW_DATA_NUM+1) to create a 50% duty cycle raw data clock. <ul style="list-style-type: none"> • 1'b0: No divide (default) • 1'b1: Further divides the raw data clock by 2
[4]	RAW_DATA_DDR	Enables raw data double-data-rate (DDR) output. In the DDR mode, raw data is valid on both pos/neg edges of raw data clock. Otherwise, raw data is valid only on positive edge of raw data clock. <ul style="list-style-type: none"> • 1'b0: Double-data-rate disabled (default) • 1'b1: Double-data-rate enabled
[3]	ENABLE_RAW_DATA_CLK	Enables raw data clock. <ul style="list-style-type: none"> • 1'b0: Raw data clock disabled (default) • 1'b1: Raw data clock enabled
[2]	ENABLE_SPDIF_CLK	Enables SPDIF encoding clock. <ul style="list-style-type: none"> • 1'b0: SPDIF clock disabled (default) • 1'b1: SPDIF clock enabled
[1:0]	RESERVED	NA



Register 6: DSD CONFIG

Bits	[7:6]	[5]	[4]	[3:2]	[1]	[0]
Default	2'b00	1'b0	1'b0	2'b00	1'b0	1'b0

Bits	Mnemonic	Description
[7:6]	RESERVED	NA
[5]	DSD_DDR	Enables DSD double-data-rate (DDR) output. In the DDR mode, DSD data is valid on both pos/neg edges of DSD clock. Otherwise, DSD data is valid only on positive edge of DSD clock.
[4]	DSD_MASTER_MODE	Enables DSD master mode and generates DSD clock. <ul style="list-style-type: none"> 1'b0: Disabled (default) 1'b1: Enabled
[3:2]	RESERVED	NA
[1]	ENABLE_DSD_CLK_CH2	Enables Ch2 DSD encoding clock. <ul style="list-style-type: none"> 1'b0: DSD clock disabled (default) 1'b1: DSD clock enabled
[0]	ENABLE_DSD_CLK_CH1	Enables Ch1 DSD encoding clock. <ul style="list-style-type: none"> 1'b0: DSD clock disabled (default) 1'b1: DSD clock enabled



Register 7: DSD AND I2S/TDM MASTER CLK CONFIG

Bits	[7:5]	[4]	[3:0]
Default	3'd0	1'b0	4'd0

Bits	Mnemonic	Description
[7:5]	MASTER_WS_SCALE	<p>In I2S/TDM master mode, tunes master BCK/WS ratio by scaling master WS. It allows more TDM slots in a fixed frame.</p> <ul style="list-style-type: none"> • 3'd0: No scale (default) • 3'd1: Scale down WS by 2 • 3'd2: Scale down WS by 4 • 3'd3: Scale down WS by 8 • 3'd4: Scale down WS by 16 • others: Reserved
[4]	DSD_CLK_DIV2	<p>Further divides the DSD clock by 2 (after divided by SELECT_DSD_NUM+1) ...to create a 50% duty cycle DSD clock.</p> <ul style="list-style-type: none"> • 1'b0: No divide (default) • 1'b1: Further divides the DSD clock by 2
[3:0]	SELECT_DSD_NUM	<p>Whole number divide value + 1 for DSD clock (SYS_CLK/divide_value). When SELECT_DSD_NUM is larger than 0, the divided clock is not a 50% duty cycle clock.</p> <ul style="list-style-type: none"> • 4'd0: Whole number divide value + 1 = 1 (default) • 4'd1: Whole number divide value + 1 = 2 • 4'd15: Whole number divide value + 1 = 16



Register 8: I2S/TDM MASTER MODE CONFIG

Bits	[7]	[6]	[5:4]	[3]	[2]	[1]	[0]
Default	1'b0	1'b0	2'd0	1'b0	1'b0	1'b0	1'b0

Bits	Mnemonic	Description
[7]	MASTER_BCK_DIV1	When enabled, master BCK is I2S/TDM master encoding clock. Otherwise, BCK is less than or equal to (I2S/TDM master encoding clock)/2 (unless when ENABLE_2X_MODE or ENABLE_4X_MODE is set). <ul style="list-style-type: none"> 1'b0: BCK is not I2S/TDM master encoding clock (default) 1'b1: BCK is I2S/TDM master encoding clock
[6]	MASTER_WS_IDLE	Sets the value of master WS when WS is idle. <ul style="list-style-type: none"> 1'b0: WS is 0 when idle (default) 1'b1: WS is 1 when idle
[5:4]	MASTER_FRAME_LENGTH	Selects the bit length in each I2S/TDM channel in master mode. <ul style="list-style-type: none"> 2'd0: 32 bit (default) 2'd2: 16 bit others: Reserved
[3]	MASTER_WS_PULSE_MODE	When enabled, master WS is a pulse signal instead of a 50% duty cycle signal. The pulse width is 1 BCK cycle. <ul style="list-style-type: none"> 1'b0: 50% duty cycle WS signal (default) 1'b1: Pulse WS signal
[2]	MASTER_BCK_INVERT	Inverts master BCK. <ul style="list-style-type: none"> 1'b0: Non-inverted (default) 1'b1: Inverted
[1]	MASTER_WS_INVERT	Inverts master WS. <ul style="list-style-type: none"> 1'b0: Non-inverted (default) 1'b1: Inverted
[0]	MASTER_MODE_ENABLE	Enables I2S/TDM master mode and generates master BCK and master WS. <ul style="list-style-type: none"> 1'b0: Disabled (default) 1'b1: Enabled



Register 9: I2S/TDM MASTER CLK CONFIG

Bits	[7]	[6:0]
Default	1'b0	7'd3

Bits	Mnemonic	Description
[7]	SELECT_I2S_TDM_HALF	<ul style="list-style-type: none"> 1'b0: Divide by SELECT_I2S_TDM_NUM + 1 (default) 1'b1: Divide by half of SELECT_I2S_TDM_NUM + 1 Note: Can only produce half of an odd number divide
[6:0]	SELECT_I2S_TDM_NUM	Whole number divide value + 1 for I2S/TDM master encoding clock (SYS_CLK/divide_value). <ul style="list-style-type: none"> 7'd0: Whole number divide value + 1 = 1 (default) 7'd1: Whole number divide value + 1 = 2 7'd127: Whole number divide value + 1 = 128

Register 10: TDM CONFIG1

Bits	[7:3]	[2]	[1]	[0]
Default	5'd0	1'b1	1'b0	1'b1

Bits	Mnemonic	Description
[7:3]	TDM_BIT_DELAY	Indicates the MSB-2 position of the data from the frame start. Valid from 5'd0 to 5'd31
[2]	TDM_VALID_EDGE	Sets on which WS edge the frame starts. <ul style="list-style-type: none"> 1'b0: Frame starts on posedge of WS 1'b1: Frame starts on negedge of WS (default)
[1]	TDM_LJ	Sets left-justified mode. <ul style="list-style-type: none"> 1'b0: No left-justified (default) 1'b1: Left-justified
[0]	ENABLE_TDM_CLK	Enables I2S/TDM encoding clock. <ul style="list-style-type: none"> 1'b0: I2S/TDM clock disabled 1'b1: I2S/TDM clock enabled (default)



Register 11: TDM CONFIG2

Bits	[7]	[6]	[5]	[4:0]
Default	1'b0	1'b0	1'b0	5'd1

Bits	Mnemonic	Description
[7]	RESERVED	NA
[6]	TDM_CASCADE	Enables TDM cascade mode. In TDM cascade mode, GPIO4 is used as the cascade data input. <ul style="list-style-type: none"> 1'b0: Disabled (default) 1'b1: Enabled
[5]	TDM_LENGTH	Sets data length in each channel. <ul style="list-style-type: none"> 1'b0: 32 bits (default) 1'b1: 16 bits
[4:0]	TDM_CH_NUM	Sets number of channels in each frame. <ul style="list-style-type: none"> 5'd0: 1 channel 5'd1: 2 channels (default) 5'd31: 32 channels

Register 12: TDM SLOT CONFIG CH1

Bits	[7]	[6:5]	[4:0]
Default	1'b0	2'd0	5'd0

Bits	Mnemonic	Description
[7]	RESERVED	NA
[6:5]	TDM_LINE_SEL_CH1	Selects ADC Ch1 data is presented on which TDM data line. <ul style="list-style-type: none"> 2'd0: TDM data line 1 - GPIO3 (default) 2'd1: TDM data line 2 - GPIO4 2'd2: TDM data line 3 - GPIO5 2'd3: TDM data line 4 - GPIO6
[4:0]	TDM_SLOT_SEL_CH1	Selects which TDM channel slot is filled by ADC Ch1 data. <ul style="list-style-type: none"> 5'd0: Slot 1 (default) 5'd1: Slot 2 5'd31: Slot 32



Register 13: TDM SLOT CONFIG CH2

Bits	[7]	[6:5]	[4:0]
Default	1'b0	2'd0	5'd1

Bits	Mnemonic	Description
[7]	RESERVED	NA
[6:5]	TDM_LINE_SEL_CH2	Selects ADC Ch2 data is presented on which TDM data line. <ul style="list-style-type: none"> 2'd0: TDM data line 1 - GPIO3 (default) 2'd1: TDM data line 2 - GPIO4 2'd2: TDM data line 3 - GPIO5 2'd3: TDM data line 4 - GPIO6
[4:0]	TDM_SLOT_SEL_CH2	Selects which TDM channel slot is filled by ADC Ch2 data. <ul style="list-style-type: none"> 5'd0: Slot 1 5'd1: Slot 2 (default) 5'd31: Slot 32

Register 16-14: RESERVED

Register 17: RAW DATA MAPPING

Bits	[7:4]	[3:2]	[1:0]
Default	4'd5	2'd1	2'd0

Bits	Mnemonic	Description
[7:4]	RESERVED	NA
[3:2]	RAW_DATA_MAPPING_CH2	Re-maps Ch2 data from Ch1 of the analog ADC data inputs. <ul style="list-style-type: none"> 2'd0: Ch2 data is from analog ADC Ch1 2'd1: Ch2 data is from analog ADC Ch2 (default) 2'd2: Reserved 2'd3: Reserved
[1:0]	RAW_DATA_MAPPING_CH1	Re-maps Ch1 data from Ch2 of the analog ADC data inputs. <ul style="list-style-type: none"> 2'd0: Ch1 data is from analog ADC Ch1 (default) 2'd1: Ch1 data is from analog ADC Ch2 2'd2: Reserved 2'd3: Reserved



Register 18: PCM DATA OUTPUT MAPPING

Bits	[7:4]	[3:2]	[1:0]
Default	4'd5	2'd1	2'd0

Bits	Mnemonic	Description
[7:4]	RESERVED	NA
[3:2]	OUTPUT_MAPPING_CH2	<p>Re-maps Ch2 PCM data output from either Ch1 or Ch2 ADC decimation paths or ASP outputs (when ASP is enabled).</p> <ul style="list-style-type: none"> 2'd0: Ch2 PCM data output is from ADC decimation path Ch1 or ASP output Ch1 2'd1: Ch2 PCM data output is from ADC decimation path Ch2 or ASP output Ch2 (default) 2'd2: Reserved 2'd3: Reserved
[1:0]	OUTPUT_MAPPING_CH1	<p>Re-maps Ch1 PCM data output from either Ch1 or Ch2 ADC decimation paths or ASP outputs (when ASP is enabled).</p> <ul style="list-style-type: none"> 2'd0: Ch1 PCM data output is from ADC decimation path Ch1 or ASP output Ch1 (default) 2'd1: Ch1 PCM data output is from ADC decimation path Ch2 or ASP output Ch2 2'd2: Reserved 2'd3: Reserved

Register 19: DSD DATA OUTPUT MAPPING

Bits	[7:4]	[3:2]	[1:0]
Default	4'd5	2'd1	2'd0

Bits	Mnemonic	Description
[7:4]	RESERVED	NA
[3:2]	DSD_MAPPING_CH2	<p>Re-maps Ch2 DSD data output from either Ch1 or Ch2 the ADC decimation paths.</p> <ul style="list-style-type: none"> 2'd0: Ch2 DSD data output is from ADC decimation path Ch1 2'd1: Ch2 DSD data output is from ADC decimation path Ch2 (default) 2'd2: Reserved 2'd3: Reserved
[1:0]	DSD_MAPPING_CH1	<p>Re-maps Ch1 DSD data output from either Ch1 or Ch2 of the ADC decimation paths.</p> <ul style="list-style-type: none"> 2'd0: Ch1 DSD data output is from ADC decimation path Ch1 (default) 2'd1: Ch1 DSD data output is from ADC decimation path Ch2 2'd2: Reserved 2'd3: Reserved



Register 20: TPDF DITHER LEVEL

Bits	[7:5]	[4:0]
Default	3'd0	5'd16

Bits	Mnemonic	Description
[7:5]	RESERVED	NA
[4:0]	DITHER_SCALE	TPDF dither level: <ul style="list-style-type: none"> • 5'd0: 16 bits • 5'd1: 17 bits • 5'd2: 18 bits • 5'd3: 19 bits • 5'd4: 20 bits • 5'd5: 21 bits • 5'd6: 22 bits • 5'd7: 23 bits • 5'd8: 24 bits • 5'd9: 25 bits • 5'd10: 26 bits • 5'd11: 27 bits • 5'd12: 28 bits • 5'd13: 29 bits • 5'd14: 30 bits • 5'd15: 31 bits • >= 5'd16: 32 bits (TPDF dither disabled) (default)



Register 22-21: DITHER MASK

Bits	[15:0]
Default	16'hFFFF

Bits	Mnemonic	Description
[15:0]	DITHER_MASK	<p>Mask off the LSB's of PCM data output.</p> <ul style="list-style-type: none"> • 16'h0000 => Quantized to 16 bits • 16'h8000 => Quantized to 17 bits • 16'hC000 => Quantized to 18 bits • 16'hE000 => Quantized to 19 bits • 16'hF000 => Quantized to 20 bits • 16'hF800 => Quantized to 21 bits • 16'hFC00 => Quantized to 22 bits • 16'hFE00 => Quantized to 23 bits • 16'hFF00 => Quantized to 24 bits • 16'hFF80 => Quantized to 25 bits • 16'hFFC0 => Quantized to 26 bits • 16'hFFE0 => Quantized to 27 bits • 16'hFFF0 => Quantized to 28 bits • 16'hFFF8 => Quantized to 29 bits • 16'hFFFC => Quantized to 30 bits • 16'hFFFE => Quantized to 31 bits • 16'hFFFF => Quantized to 32 bits (default) • others: Reserved

Register 23: FS GEN PHASE CONTROL

Bits	[7]	[6:0]
Default	1'b0	7'd4

Bits	Mnemonic	Description
[7]	DSD_SYNC_TO_1FS	<p>In DSD mode, when enabled, DSD logic is sync to an 1FS signal input from GPIO2. When not enabled, DSD logic is sync to DSD clock input from GPIO1.</p> <ul style="list-style-type: none"> • 1'b0: DSD logic is sync to DSD clock input from GPIO1 (default) • 1'b1: DSD logic is sync to 1FS signal input from GPIO2
[6:0]	RESERVED	NA

Register 26-24: RESERVED

**Register 27: INTERRUPT**

Bits	[7:6]	[5]	[4]	[3:2]	[1]	[0]
Default	1'b0	1'b0	1'b0	1'b0	1'b0	1'b0

Bits	Mnemonic	Description
[7:6]	RESERVED	NA
[5]	INTERRUPT_CLEAR_CH2_CLIP_DETECTION	Clears the clip detection interrupt of ADC Ch2 <ul style="list-style-type: none"> 1'b0: Interrupt held if asserted and not masked (default) 1'b1: Interrupt cleared
[4]	INTERRUPT_CLEAR_CH1_CLIP_DETECTION	Clears the clip detection interrupt of ADC Ch1 <ul style="list-style-type: none"> 1'b0: Interrupt held if asserted and not masked (default) 1'b1: Interrupt cleared
[3:2]	RESERVED	NA
[1]	INTERRUPT_MASK_CH2_CLIP_DETECTION	Masks the clip detection interrupt of ADC Ch2 <ul style="list-style-type: none"> 1'b0: Interrupt masked (default) 1'b1: Interrupt held if asserted
[0]	INTERRUPT_MASK_CH1_CLIP_DETECTION	Masks the clip detection interrupt of ADC Ch1 <ul style="list-style-type: none"> 1'b0: Interrupt masked (default) 1'b1: Interrupt held if asserted

Register 32-28: SPDIF CONFIG

Bits	[39:0]
Default	40'd0

Bits	Mnemonic	Description
[39:0]	SPDIF_CS	Configures SPDIF sub-code bits.

Register 33: DSD DITHER SCALE AND SYNC CONTROL

Bits	[7]	[6]	[5]	[4:0]
Default	1'b0	1'b0	1'b0	5'd21

Bits	Mnemonic	Description
[7]	SYNC_POSEDGE_FRAME	Selects the logic is sync to which edge of the sync reference signal. <ul style="list-style-type: none"> 1'b0: Sync to negative edge of the sync reference (default) 1'b1: Sync to positive edge of the sync reference
[6]	DISABLE_SYNC_REF	Disables the sync reference. <ul style="list-style-type: none"> 1'b0: Sync reference enabled (default) 1'b1: Sync reference disabled
[5]	FORCE_FIR_SYNC	Forces FIR to re-sync to the reference. <ul style="list-style-type: none"> 1'b0: No force (default) 1'b1: Forces FIR to re-sync
[4:0]	DSD_DITHER_SCALE	DSD noise shaped dither scale.



Register 34: SYNC CONTROL

Bits	[7]	[6]	[5]	[4]	[3]	[2]	[1]	[0]
Default	1'b0	1'b0	1'b0	1'b1	1'b1	1'b1	1'b1	1'b1

Bits	Mnemonic	Description
[7]	AUTO_ADC_CLKDIV_SYNC	When enabled, the analog ADC clock divider is only allowed to change synchronously to the reference. <ul style="list-style-type: none"> 1'b0: Auto sync disabled (default) 1'b1: Auto sync enabled
[6]	AUTO_CLK_IADC_PHASE_SYNC	Allows phase of CLK_IADC to be tuned automatically according to ADC input data. Only used when SYS_CLK is faster than CLK_IADC. <ul style="list-style-type: none"> 1'b0: CLK_IADC phase tuning disabled (default) 1'b1: Auto CLK_IADC phase tuning
[5]	AUTO_DSD_PHASE_SYNC	Uses DSD clock input from GPIO1 as the sync reference, unless DSD_SYNC_TO_1FS is set. <ul style="list-style-type: none"> 1'b0: DSD clock is not the sync reference (default) 1'b1: DSD clock is the sync reference, unless DSD_SYNC_TO_1FS is set
[4]	AUTO_WS_PHASE_SYNC	Uses WS input from GPIO2 as the sync reference, if AUTO_DSD_PHASE_SYNC is not set. <ul style="list-style-type: none"> 1'b0: WS is not the sync reference 1'b1: WS is the sync reference, if AUTO_DSD_PHASE_SYNC is not set (default)
[3]	AUTO_ICG_EN_SYNC	When enabled, the clock dividers and ADC enables are only allowed to change synchronously to the reference. <ul style="list-style-type: none"> 1'b0: Auto sync disabled 1'b1: Auto sync enabled (default)
[2]	AUTO_ICG_SYNC	Allows programmable clock dividers to auto sync to the reference. <ul style="list-style-type: none"> 1'b0: Auto sync disabled 1'b1: Auto sync enabled (default)
[1]	AUTO_FIR_SYNC	Allows FIR to auto sync to the reference. <ul style="list-style-type: none"> 1'b0: Auto sync disabled 1'b1: Auto sync enabled (default)
[0]	AUTO_FS_SYNC	Allows FS signals to auto sync to the reference. <ul style="list-style-type: none"> 1'b0: Auto sync disabled 1'b1: Auto sync enabled (default)



ASP Registers

Register 35: ASP1 CONFIG

Bits	[7:6]	[5:1]	[0]
Default	2'b00	5'd0	1'b0

Bits	Mnemonic	Description
[7:6]	RESERVED	NA
[5:1]	SELECT_ASP1_NUM	Whole number divide value + 1 for ASP1 clock (SYS_CLK/divide_value). <ul style="list-style-type: none"> 5'd0: Whole number divide value + 1 = 1 (default) 5'd1: Whole number divide value + 1 = 2 5'd31: Whole number divide value + 1 = 32
[0]	ENABLE_ASP1_CLK	Enables ASP1 clock. <ul style="list-style-type: none"> 1'b0: Disabled (default) 1'b1: Enabled

Register 36: ASP2 CONFIG

Bits	[7:6]	[5:1]	[0]
Default	2'b00	5'd0	1'b0

Bits	Mnemonic	Description
[7:6]	RESERVED	NA
[5:1]	SELECT_ASP2_NUM	Whole number divide value + 1 for ASP2 clock (SYS_CLK/divide_value). <ul style="list-style-type: none"> 5'd0: Whole number divide value + 1 = 1 (default) 5'd1: Whole number divide value + 1 = 2 5'd31: Whole number divide value + 1 = 32
[0]	ENABLE_ASP2_CLK	Enables ASP2 clock. <ul style="list-style-type: none"> 1'b0: Disabled (default) 1'b1: Enabled



Register 37: ASP ENABLE AND PROGRAMMING CONTROL

Bits	[7]	[6]	[5]	[4]	[3]	[2]	[1]	[0]
Default	1'b0	1'b0	1'b0	1'b0	1'b0	1'b0	1'b0	1'b0

Bits	Mnemonic	Description
[7]	ASP2_COEFF_WE	Enables writing to the ASP2 coeff RAM. <ul style="list-style-type: none"> 1'b0: Writing disabled (default) 1'b1: Writing enabled
[6]	ASP1_COEFF_WE	Enables writing to the ASP1 coeff RAM. <ul style="list-style-type: none"> 1'b0: Writing disabled (default) 1'b1: Writing enabled
[5]	ASP2_PROGRAM_WE	Enables writing to the ASP2 program memory. <ul style="list-style-type: none"> 1'b0: Writing disabled (default) 1'b1: Writing enabled
[4]	ASP1_PROGRAM_WE	Enables writing to the ASP1 program memory. <ul style="list-style-type: none"> 1'b0: Writing disabled (default) 1'b1: Writing enabled
[3]	ASP2_PROGRAM_EN	Enables ASP2 program memory and coeff RAM programming before its output is enabled and used in the signal path. <ul style="list-style-type: none"> 1'b0: Programming disabled (default) 1'b1: Programming enabled
[2]	ASP1_PROGRAM_EN	Enables ASP1 program memory and coeff RAM programming before its output is enabled and used in the signal path. <ul style="list-style-type: none"> 1'b0: Programming disabled (default) 1'b1: Programming enabled
[1]	ENABLE_ASP2	Selects whether ASP2 is enabled and used in the signal path or disabled and bypassed. <ul style="list-style-type: none"> 1'b0: ASP2 is disabled and bypassed (default) 1'b1: ASP2 is enabled. Data is processed by ASP2 before output
[0]	ENABLE_ASP1	Selects whether ASP1 is enabled and used in the signal path or disabled and bypassed. <ul style="list-style-type: none"> 1'b0: ASP1 is disabled and bypassed (default) 1'b1: ASP1 is enabled. Data is processed by ASP1 before output

Register 39-38: ASP PROGRAM ADDR

Bits	[15:9]	[8:0]
Default	7'd0	9'd0

Bits	Mnemonic	Description
[15:9]	RESERVED	NA
[8:0]	ASP_PROGRAM_ADDR	Selects the program address when writing custom program codes for either ASP.

**Register 41-40: ASP PROGRAM**

Bits	[15:14]	[13:0]
Default	2'd0	14'd0

Bits	Mnemonic	Description
[15:14]	RESERVED	NA
[13:0]	ASP_PROGRAM_IN	A 14 bits program instruction that will be written to the address of either ASP defined by ASP_PROGRAM_ADDR.

Register 42: ASP COEFF ADDR

Bits	[7:6]	[5:0]
Default	2'd0	6'd0

Bits	Mnemonic	Description
[7:6]	RESERVED	NA
[5:0]	ASP_COEFF_ADDR	Selects the coefficient address when writing custom coefficient for either ASP.

Register 50-43: ASP COEFF

Bits	[63:32]	[31:0]
Default	32'd0	32'd0

Bits	Mnemonic	Description
[63:32]	ASP_COEFF_MSB	A 32 bits coefficient that will be written to the address defined by ASP_COEFF_ADDR. These last 32 bits are typically used for the channel 2 data.
[31:0]	ASP_COEFF_LSB	A 32 bits coefficient that will be written to the address defined by ASP_COEFF_ADDR. These first 32 bits are typically used for the channel 1 data.

Register 51: ASP1 CH1 STEP SIZE

Bits	[7:0]
Default	8'd0

Bits	Mnemonic	Description
[7:0]	ASP1_CH1_STEP_SIZE	Programmable value to be used in multiplications for Ch1 within ASP1.

**Register 52: ASP1 CH2 STEP SIZE**

Bits	[7:0]
Default	8'd0

Bits	Mnemonic	Description
[7:0]	ASP1_CH2_STEP_SIZE	Programmable value to be used in multiplications for Ch2 within ASP1.

Register 53: ASP2 CH1 STEP SIZE

Bits	[7:0]
Default	8'd0

Bits	Mnemonic	Description
[7:0]	ASP2_CH1_STEP_SIZE	Programmable value to be used in multiplications for Ch1 within ASP2.

Register 54: ASP2 CH2 STEP SIZE

Bits	[7:0]
Default	8'd0

Bits	Mnemonic	Description
[7:0]	ASP2_CH2_STEP_SIZE	Programmable value to be used in multiplications for Ch2 within ASP2.

Register 55: ASP1 CUSTOM ADDR

Bits	[7:6]	[5:0]
Default	2'd0	6'd0

Bits	Mnemonic	Description
[7:6]	RESERVED	NA
[5:0]	ASP1_CUSTOM_ADDR	Custom address that can be accessed through the MOV_RAM1_ADDR instruction in ASP1.

Register 56: ASP1 CUSTOM ADDR2

Bits	[7:6]	[5:0]
Default	2'd0	6'd0

Bits	Mnemonic	Description
[7:6]	RESERVED	NA
[5:0]	ASP1_CUSTOM_ADDR2	Custom address that can be accessed through the MOV_RAM2_ADDR instruction in ASP1.

**Register 57: ASP2 CUSTOM ADDR**

Bits	[7:6]	[5:0]
Default	2'd0	6'd0

Bits	Mnemonic	Description
[7:6]	RESERVED	NA
[5:0]	ASP2_CUSTOM_ADDR	Custom address that can be accessed through the MOV_RAM1_ADDR instruction in ASP2.

Register 58: ASP2 CUSTOM ADDR2

Bits	[7:6]	[5:0]
Default	2'd0	6'd0

Bits	Mnemonic	Description
[7:6]	RESERVED	NA
[5:0]	ASP2_CUSTOM_ADDR2	Custom address that can be accessed through the MOV_RAM2_ADDR instruction in ASP2.



Delay Line Registers

Register 60-59: I2S DECODER CONFIG

Bits	[15:14]	[13:12]	[11]	[10]	[9:0]
Default	2'd0	2'd0	1'b0	1'b0	10'd0

Bits	Mnemonic	Description
[15:14]	I2S_DECODER_CH_SEL	Sets the number of bits in a channel <ul style="list-style-type: none"> 2'd0: 32 bits (default) 2'd1: 24 bits 2'd2: 16 bits 2'd3: Reserved
[13:12]	I2S_DECODER_WORD_SEL	Sets the number of bits of data <ul style="list-style-type: none"> 2'd0: 32 bits (default) 2'd1: 24 bits 2'd2: 16 bits 2'd3: Reserved
[11]	I2S_DECODER_POSEDGE_FRAME	Sets where the frame starts <ul style="list-style-type: none"> 1'b0: Indicates frame starts on negedge of WS (default) 1'b1: Indicates frame starts on posedge of WS
[10]	ENABLE_I2S_DECODER	Enables I2S decoder. <ul style="list-style-type: none"> 1'b0: Disabled (default) 1'b1: Enabled
[9:0]	I2S_DECODER_BIT_START	Indicates the MSB-2 position of the data from the frame start. Valid from 10'h0 to 10'h3FF

Register 62-61: DELAY LINE CONFIG

Bits	[15:10]	[9]	[8:0]
Default	6'd14	1'b0	9'd0

Bits	Mnemonic	Description
[15:10]	RESERVED	NA
[9]	ENABLE_CLK_DL	Enables delay line clock and data output. <ul style="list-style-type: none"> 1'b0: Disabled (default) 1'b1: Enabled
[8:0]	PROG_DELAY_LINE	Sets the length of the delay line. <ul style="list-style-type: none"> 9'd0: No delay (default) 9'd1: Delay the I2S input data by 1 sample 9'd2: Delay the I2S input data by 2 samples 9'd511: Delay the I2S input data by 511 samples



Register 63: ADC CH1A CONFIG 1

Bits	[7:4]	[3]	[2]	[1]	[0]
Default	4'd0	1'b0	1'b0	1'b0	1'b0

Bits	Mnemonic	Description
[7:4]	ADC_INT_SEL_CH1A	ADC Integrator Control <ul style="list-style-type: none"> Program to 4'b1011 for optimum performance
[3]	ADC_EN_FB_CH1A	Enable ADC 1A feedback path, active high <ul style="list-style-type: none"> 1'b0: Disabled (default) 1'b1: Enabled
[2]	RESERVED	NA
[1]	ADC_EN_INT_CH1A	Enable for INT for Channel 1A. Default is 0, INT is not enabled. <ul style="list-style-type: none"> Set to 1'b1 to enable.
[0]	ADC_EN_CH1A	Enable for Comparator and logic for Channel 1A. Default is 0, Comparator and logic are not enabled <ul style="list-style-type: none"> Set to 1'b1 to enable.

Register 64: ADC CH1A CONFIG 2

Bits	[7:5]	[4:3]	[2]	[1]	[0]
Default	3'd0	2'd0	1'b0	1'b0	1'b0

Bits	Mnemonic	Description
[7:5]	ADC_COMP_SEL_CH1A	Sets the gain of Comparator of Channel 1A. <ul style="list-style-type: none"> Program to 3'b001 for optimum performance
[4:3]	ADC_SUM_SEL_CH1A	Sets the bandwidth of the summing amplifier for Channel 1A. <ul style="list-style-type: none"> Program to 2'b11 for optimum performance
[2]	ADC_USE_DITHER_EXT_CH1A	Enable the external dither for Channel 1A. <ul style="list-style-type: none"> Default value is 0.
[1]	ADC_USE_DITHER_CH1A	Enable the dither for Channel 1A. <ul style="list-style-type: none"> Default value is 0, dither is not enabled
[0]	ADC_USE_STATE_CH1A	Use state as logic output for Channel 1A. <ul style="list-style-type: none"> Program to 1'b1 for optimum performance



Register 65: ADC CH2A CONFIG 1

Bits	[7:4]	[3]	[2]	[1]	[0]
Default	4'd0	1'b0	1'b0	1'b0	1'b0

Bits	Mnemonic	Description
[7:4]	ADC_INT_SEL_CH2A	ADC Integrator Control <ul style="list-style-type: none"> Program to 4'b1011 for optimum performance
[3]	ADC_EN_FB_CH2A	Enable ADC 2A feedback path, active high <ul style="list-style-type: none"> 1'b0: Disabled (default) 1'b1: Enabled
[2]	RESERVED	NA
[1]	ADC_EN_INT_CH2A	Enable for INT for Channel 2A. Default is 0, INT is not enabled. <ul style="list-style-type: none"> Set to 1'b1 to enable.
[0]	ADC_EN_CH2A	Enable for Comparator and logic for Channel 2A. Default is 0, Comparator and logic are not enabled <ul style="list-style-type: none"> Set to 1'b1 to enable.

Register 66: ADC CH2A CONFIG 2

Bits	[7:5]	[4:3]	[2]	[1]	[0]
Default	3'd0	2'd0	1'b0	1'b0	1'b0

Bits	Mnemonic	Description
[7:5]	ADC_COMP_SEL_CH2A	Sets the gain of Comparator of Channel 2A. <ul style="list-style-type: none"> Program to 3'b001 for optimum performance
[4:3]	ADC_SUM_SEL_CH2A	Sets the bandwidth of the summing amplifier for Channel 2A. <ul style="list-style-type: none"> Program to 2'b11 for optimum performance
[2]	ADC_USE_DITHER_EXT_CH2A	Enable the external dither for Channel 2A. <ul style="list-style-type: none"> Default value is 0.
[1]	ADC_USE_DITHER_CH2A	Enable the dither for Channel 2A. <ul style="list-style-type: none"> Default value is 0, dither is not enabled
[0]	ADC_USE_STATE_CH2A	Use state as logic output for Channel 2A. <ul style="list-style-type: none"> Program to 1'b1 for optimum performance



Register 67: ADC CH1B CONFIG 1

Bits	[7:4]	[3]	[2]	[1]	[0]
Default	4'd0	1'b0	1'b0	1'b0	1'b0

Bits	Mnemonic	Description
[7:4]	ADC_INT_SEL_CH1B	ADC Integrator Control <ul style="list-style-type: none"> Program to 4'b1011 for optimum performance
[3]	ADC_EN_FB_CH1B	Enable ADC 1B feedback path, active high <ul style="list-style-type: none"> 1'b0: Disabled (default) 1'b1: Enabled
[2]	RESERVED	NA
[1]	ADC_EN_INT_CH1B	Enable for INT for Channel 1B. Default is 0, INT is not enabled. <ul style="list-style-type: none"> Set to 1'b1 to enable.
[0]	ADC_EN_CH1B	Enable for Comparator and logic for Channel 1B. Default is 0, Comparator and logic are not enabled <ul style="list-style-type: none"> Set to 1'b1 to enable.

Register 68: ADC CH1B CONFIG 2

Bits	[7:5]	[4:3]	[2]	[1]	[0]
Default	3'd0	2'd0	1'b0	1'b0	1'b0

Bits	Mnemonic	Description
[7:5]	ADC_COMP_SEL_CH1B	Sets the gain of Comparator of Channel 1B. <ul style="list-style-type: none"> Program to 3'b001 for optimum performance
[4:3]	ADC_SUM_SEL_CH1B	Sets the bandwidth of the summing amplifier for Channel 1B. <ul style="list-style-type: none"> Program to 2'b11 for optimum performance
[2]	ADC_USE_DITHER_EXT_CH1B	Enable the external dither for Channel 1B. <ul style="list-style-type: none"> Default value is 0.
[1]	ADC_USE_DITHER_CH1B	Enable the dither for Channel 1B. <ul style="list-style-type: none"> Default value is 0, dither is not enabled
[0]	ADC_USE_STATE_CH1B	Use state as logic output for Channel 1B. <ul style="list-style-type: none"> Program to 1'b1 for optimum performance



Register 69: ADC CH2B CONFIG 1

Bits	[7:4]	[3]	[2]	[1]	[0]
Default	4'd0	1'b0	1'b0	1'b0	1'b0

Bits	Mnemonic	Description
[7:4]	ADC_INT_SEL_CH2B	ADC Integrator Control <ul style="list-style-type: none"> Program to 4'b1011 for optimum performance
[3]	ADC_EN_FB_CH2B	Enable ADC 2B feedback path, active high <ul style="list-style-type: none"> 1'b0: Disabled (default) 1'b1: Enabled
[2]	RESERVED	NA
[1]	ADC_EN_INT_CH2B	Enable for INT for Channel 2B. Default is 0, INT is not enabled. <ul style="list-style-type: none"> Set to 1'b1 to enable.
[0]	ADC_EN_CH2B	Enable for Comparator and logic for Channel 2B. Default is 0, Comparator and logic are not enabled <ul style="list-style-type: none"> Set to 1'b1 to enable.

Register 70: ADC CH2B CONFIG 2

Bits	[7:5]	[4:3]	[2]	[1]	[0]
Default	3'd0	2'd0	1'b0	1'b0	1'b0

Bits	Mnemonic	Description
[7:5]	ADC_COMP_SEL_CH2B	Sets the gain of Comparator of Channel 2B. <ul style="list-style-type: none"> Program to 3'b001 for optimum performance
[4:3]	ADC_SUM_SEL_CH2B	Sets the bandwidth of the summing amplifier for Channel 2B. <ul style="list-style-type: none"> Program to 2'b11 for optimum performance
[2]	ADC_USE_DITHER_EXT_CH2B	Enable the external dither for Channel 2B. <ul style="list-style-type: none"> Default value is 0.
[1]	ADC_USE_DITHER_CH2B	Enable the dither for Channel 2B. <ul style="list-style-type: none"> Default value is 0, dither is not enabled
[0]	ADC_USE_STATE_CH2B	Use state as logic output for Channel 2B. <ul style="list-style-type: none"> Program to 1'b1 for optimum performance



Register 71: ADC COMMON MODE CONFIG

Bits	[7:6]	[5:4]	[3:2]	[1:0]
Default	2'd0	2'd0	2'd0	2'd0

Bits	Mnemonic	Description
[7:6]	ADC_CM_SEL_CH2B	Set the common mode voltages for channel 2B internal analog circuitry. <ul style="list-style-type: none"> • Set to 2'b3 for optimal operation
[5:4]	ADC_CM_SEL_CH1B	Set the common mode voltages for channel 1B internal analog circuitry. <ul style="list-style-type: none"> • Set to 2'b3 for optimal operation
[3:2]	ADC_CM_SEL_CH2A	Set the common mode voltages for channel 2A internal analog circuitry. <ul style="list-style-type: none"> • Set to 2'b3 for optimal operation
[1:0]	ADC_CM_SEL_CH1A	Set the common mode voltages for channel 1A internal analog circuitry. <ul style="list-style-type: none"> • Set to 2'b3 for optimal operation

Register 72: RESERVED



Register 73: VREF CONFIG

Bits	[7:6]	[5]	[4]	[3]	[2]	[1]	[0]
Default	2'd0	1'b0	1'b0	1'b0	1'b0	1'b0	1'b0

Bits	Mnemonic	Description
[7:6]	RESERVED	NA
[5]	AREF_PDB	ADC reference voltage enable, active high <ul style="list-style-type: none"> 1'b0: Disabled (default) 1'b1: Enabled
[4]	PDB_AREGR	ADC regulator R enable, active high <ul style="list-style-type: none"> 1'b0: Disabled (default) 1'b1: Enabled
[3]	PDB_AREGL	ADC regulator L enable, active high <ul style="list-style-type: none"> 1'b0: Disabled (default) 1'b1: Enabled
[2]	FC_LN	Enable the low noise mode for the DAC reference voltage, active high <ul style="list-style-type: none"> 1'b0: Disabled (default) 1'b1: Enabled
[1]	ENFCB_R	Enable the fast charge of the ADC regulator R, active low <ul style="list-style-type: none"> 1'b0: Enabled (default) 1'b1: Disabled
[0]	ENFCB_L	Enable the fast charge of the ADC regulator L, active low <ul style="list-style-type: none"> 1'b0: Enabled (default) 1'b1: Disabled



GPIO Registers

Register 74: GPIO1/2 CONFIG

Bits	[7:4]	[3:0]
Default	4'd0	4'd0

Bits	Mnemonic	Description
[7:4]	GPIO2_CFG	Configure GPIO2 GPIO Function Selection <ul style="list-style-type: none"> • 4'd0 - Analog outputs off - shutdown (default) • 4'd1 - Aux inputs - input • 4'd2 - Aux outputs - output • 4'd3 - Raw data outputs - output • 4'd4 - Interrupt Ch1 clip - output • 4'd5 - Interrupt Ch2 clip - output • 4'd6 - Reserved • 4'd7 - Reserved • 4'd8 - SPDIF data output - output • 4'd9 - Output PWM1 - output • 4'd10 - Output PWM2 - output • 4'd11 - Output PWM3 - output • 4'd12 - CLK_IADC - output • 4'd13 - CLK_ADC - output • 4'd14 - Output 0 - output • 4'd15 - Output 1 - output
[3:0]	GPIO1_CFG	Configure GPIO1 GPIO Function Selection <ul style="list-style-type: none"> • 4'd0 - Analog outputs off - shutdown (default) • 4'd1 - Aux inputs - input • 4'd2 - Aux outputs - output • 4'd3 - Raw data outputs - output • 4'd4 - Interrupt Ch1 clip - output • 4'd5 - Interrupt Ch2 clip - output • 4'd6 - Reserved • 4'd7 - Reserved • 4'd8 - SPDIF data output - output • 4'd9 - Output PWM1 - output • 4'd10 - Output PWM2 - output • 4'd11 - Output PWM3 - output • 4'd12 - CLK_IADC - output • 4'd13 - CLK_ADC - output • 4'd14 - Output 0 - output • 4'd15 - Output 1 - output



Register 75: GPIO3/4 CONFIG

Bits	[7:4]	[3:0]
Default	4'd0	4'd0

Bits	Mnemonic	Description
[7:4]	GPIO4_CFG	Configure GPIO4 GPIO Function Selection <ul style="list-style-type: none"> • 4'd0 - Analog outputs off - shutdown (default) • 4'd1 - Aux inputs - input • 4'd2 - Aux outputs - output • 4'd3 - Raw data outputs - output • 4'd4 - Interrupt Ch1 clip - output • 4'd5 - Interrupt Ch2 clip - output • 4'd6 - Reserved • 4'd7 - Reserved • 4'd8 - SPDIF data output - output • 4'd9 - Output PWM1 - output • 4'd10 - Output PWM2 - output • 4'd11 - Output PWM3 - output • 4'd12 - CLK_IADC - output • 4'd13 - CLK_ADC - output • 4'd14 - Output 0 - output • 4'd15 - Output 1 - output
[3:0]	GPIO3_CFG	Configure GPIO3 GPIO Function Selection <ul style="list-style-type: none"> • 4'd0 - Analog outputs off - shutdown (default) • 4'd1 - Aux inputs - input • 4'd2 - Aux outputs - output • 4'd3 - Raw data outputs - output • 4'd4 - Interrupt Ch1 clip - output • 4'd5 - Interrupt Ch2 clip - output • 4'd6 - Reserved • 4'd7 - Reserved • 4'd8 - SPDIF data output - output • 4'd9 - Output PWM1 - output • 4'd10 - Output PWM2 - output • 4'd11 - Output PWM3 - output • 4'd12 - CLK_IADC - output • 4'd13 - CLK_ADC - output • 4'd14 - Output 0 - output • 4'd15 - Output 1 - output



Register 76: GPIO5/6 CONFIG

Bits	[7:4]	[3:0]
Default	4'd0	4'd0

Bits	Mnemonic	Description
[7:4]	GPIO6_CFG	Configure GPIO6 GPIO Function Selection <ul style="list-style-type: none"> • 4'd0 - Analog outputs off - shutdown (default) • 4'd1 - Aux inputs - input • 4'd2 - Aux outputs - output • 4'd3 - Raw data outputs - output • 4'd4 - Interrupt Ch1 clip - output • 4'd5 - Interrupt Ch2 clip - output • 4'd6 - Reserved • 4'd7 - Reserved • 4'd8 - SPDIF data output - output • 4'd9 - Output PWM1 - output • 4'd10 - Output PWM2 - output • 4'd11 - Output PWM3 - output • 4'd12 - CLK_IADC - output • 4'd13 - CLK_ADC - output • 4'd14 - Output 0 - output • 4'd15 - Output 1 - output
[3:0]	GPIO5_CFG	Configure GPIO5 GPIO Function Selection <ul style="list-style-type: none"> • 4'd0 - Analog outputs off - shutdown (default) • 4'd1 - Aux inputs - input • 4'd2 - Aux outputs - output • 4'd3 - Raw data outputs - output • 4'd4 - Interrupt Ch1 clip - output • 4'd5 - Interrupt Ch2 clip - output • 4'd6 - Reserved • 4'd7 - Reserved • 4'd8 - SPDIF data output - output • 4'd9 - Output PWM1 - output • 4'd10 - Output PWM2 - output • 4'd11 - Output PWM3 - output • 4'd12 - CLK_IADC - output • 4'd13 - CLK_ADC - output • 4'd14 - Output 0 - output • 4'd15 - Output 1 - output



Register 77: GPIO7/8 CONFIG

Bits	[7:4]	[3:0]
Default	4'd0	4'd0

Bits	Mnemonic	Description
[7:4]	GPIO8_CFG	Configure GPIO8 GPIO Function Selection <ul style="list-style-type: none"> • 4'd0 - Analog outputs off - shutdown (default) • 4'd1 - Aux inputs - input • 4'd2 - Aux outputs - output • 4'd3 - Raw data outputs - output • 4'd4 - Interrupt Ch1 clip - output • 4'd5 - Interrupt Ch2 clip - output • 4'd6 - Reserved • 4'd7 - Reserved • 4'd8 - SPDIF data output - output • 4'd9 - Output PWM1 - output • 4'd10 - Output PWM2 - output • 4'd11 - Output PWM3 - output • 4'd12 - CLK_IADC - output • 4'd13 - CLK_ADC - output • 4'd14 - Output 0 - output • 4'd15 - Output 1 - output
[3:0]	GPIO7_CFG	Configure GPIO7 GPIO Function Selection <ul style="list-style-type: none"> • 4'd0 - Analog outputs off - shutdown (default) • 4'd1 - Aux inputs - input • 4'd2 - Aux outputs - output • 4'd3 - Raw data outputs - output • 4'd4 - Interrupt Ch1 clip - output • 4'd5 - Interrupt Ch2 clip - output • 4'd6 - Reserved • 4'd7 - Reserved • 4'd8 - SPDIF data output - output • 4'd9 - Output PWM1 - output • 4'd10 - Output PWM2 - output • 4'd11 - Output PWM3 - output • 4'd12 - CLK_IADC - output • 4'd13 - CLK_ADC - output • 4'd14 - Output 0 - output • 4'd15 - Output 1 - output



Register 78: GPIO9/10 CONFIG

Bits	[7:4]	[3:0]
Default	4'd0	4'd0

Bits	Mnemonic	Description
[7:4]	GPIO10_CFG	Configure GPIO10 GPIO Function Selection <ul style="list-style-type: none"> • 4'd0 - Analog outputs off - shutdown (default) • 4'd1 - Aux inputs - input • 4'd2 - Aux outputs - output • 4'd3 - Raw data outputs - output • 4'd4 - Interrupt Ch1 clip - output • 4'd5 - Interrupt Ch2 clip - output • 4'd6 - Reserved • 4'd7 - Reserved • 4'd8 - SPDIF data output - output • 4'd9 - Output PWM1 - output • 4'd10 - Output PWM2 - output • 4'd11 - Output PWM3 - output • 4'd12 - CLK_IADC - output • 4'd13 - CLK_ADC - output • 4'd14 - Output 0 - output • 4'd15 - Output 1 - output
[3:0]	GPIO9_CFG	Configure GPIO9 GPIO Function Selection <ul style="list-style-type: none"> • 4'd0 - Analog outputs off - shutdown (default) • 4'd1 - Aux inputs - input • 4'd2 - Aux outputs - output • 4'd3 - Raw data outputs - output • 4'd4 - Interrupt Ch1 clip - output • 4'd5 - Interrupt Ch2 clip - output • 4'd6 - Reserved • 4'd7 - Reserved • 4'd8 - SPDIF data output - output • 4'd9 - Output PWM1 - output • 4'd10 - Output PWM2 - output • 4'd11 - Output PWM3 - output • 4'd12 - CLK_IADC - output • 4'd13 - CLK_ADC - output • 4'd14 - Output 0 - output • 4'd15 - Output 1 - output



Register 79: GPIO11 CONFIG

Bits	[7:4]	[3:0]
Default	4'd0	4'd0

Bits	Mnemonic	Description
[7:4]	RESERVED	NA
[3:0]	GPIO11_CFG	Configure GPIO11 GPIO Function Selection <ul style="list-style-type: none"> • 4'd0 - Analog outputs off - shutdown (default) • 4'd1 - Aux inputs - input • 4'd2 - Aux outputs - output • 4'd3 - Raw data outputs - output • 4'd4 - Interrupt Ch1 clip - output • 4'd5 - Interrupt Ch2 clip - output • 4'd6 - Reserved • 4'd7 - Reserved • 4'd8 - SPDIF data output - output • 4'd9 - Output PWM1 - output • 4'd10 - Output PWM2 - output • 4'd11 - Output PWM3 - output • 4'd12 - CLK_IADC - output • 4'd13 - CLK_ADC - output • 4'd14 - Output 0 - output • 4'd15 - Output 1 - output

Register 81-80: RESERVED



Register 83-82: INVERT GPIO

Bits	[15:11]	[10]	[9]	[8]	[7]	[6]	[5]	[4]	[3]	[2]	[1]	[0]
Default	5'b00000	1'b0	1'b0	1'b0	1'b0	1'b0	1'b0	1'b0	1'b0	1'b0	1'b0	1'b0

Bits	Mnemonic	Description
[15:11]	RESERVED	NA
[10]	INVERT_GPIO11	<ul style="list-style-type: none"> 1'b0: Non-invert (default) 1'b1: Invert GPIO11 output
[9]	INVERT_GPIO10	<ul style="list-style-type: none"> 1'b0: Non-invert (default) 1'b1: Invert GPIO10 output
[8]	INVERT_GPIO9	<ul style="list-style-type: none"> 1'b0: Non-invert (default) 1'b1: Invert GPIO9 output
[7]	INVERT_GPIO8	<ul style="list-style-type: none"> 1'b0: Non-invert (default) 1'b1: Invert GPIO8 output
[6]	INVERT_GPIO7	<ul style="list-style-type: none"> 1'b0: Non-invert (default) 1'b1: Invert GPIO7 output
[5]	INVERT_GPIO6	<ul style="list-style-type: none"> 1'b0: Non-invert (default) 1'b1: Invert GPIO6 output
[4]	INVERT_GPIO5	<ul style="list-style-type: none"> 1'b0: Non-invert (default) 1'b1: Invert GPIO5 output
[3]	INVERT_GPIO4	<ul style="list-style-type: none"> 1'b0: Non-invert (default) 1'b1: Invert GPIO4 output
[2]	INVERT_GPIO3	<ul style="list-style-type: none"> 1'b0: Non-invert (default) 1'b1: Invert GPIO3 output
[1]	INVERT_GPIO2	<ul style="list-style-type: none"> 1'b0: Non-invert (default) 1'b1: Invert GPIO2 output
[0]	INVERT_GPIO1	<ul style="list-style-type: none"> 1'b0: Non-invert (default) 1'b1: Invert GPIO1 output



Register 85-84: GPIO WEAK ENABLE

Bits	[15:11]	[10]	[9]	[8]	[7]	[6]	[5]	[4]	[3]	[2]	[1]	[0]
Default	5'b00000	1'b0	1'b0	1'b0	1'b0	1'b0	1'b0	1'b0	1'b0	1'b0	1'b0	1'b0

Bits	Mnemonic	Description
[15:11]	RESERVED	NA
[10]	GPIO11_WK_EN	<ul style="list-style-type: none"> 1'b0: GPIO11 weak keeper disabled (default) 1'b1: GPIO11 weak keeper enabled
[9]	GPIO10_WK_EN	<ul style="list-style-type: none"> 1'b0: GPIO10 weak keeper disabled (default) 1'b1: GPIO10 weak keeper enabled
[8]	GPIO9_WK_EN	<ul style="list-style-type: none"> 1'b0: GPIO9 weak keeper disabled (default) 1'b1: GPIO9 weak keeper enabled
[7]	GPIO8_WK_EN	<ul style="list-style-type: none"> 1'b0: GPIO8 weak keeper disabled (default) 1'b1: GPIO8 weak keeper enabled
[6]	GPIO7_WK_EN	<ul style="list-style-type: none"> 1'b0: GPIO7 weak keeper disabled (default) 1'b1: GPIO7 weak keeper enabled
[5]	GPIO6_WK_EN	<ul style="list-style-type: none"> 1'b0: GPIO6 weak keeper disabled (default) 1'b1: GPIO6 weak keeper enabled
[4]	GPIO5_WK_EN	<ul style="list-style-type: none"> 1'b0: GPIO5 weak keeper disabled (default) 1'b1: GPIO5 weak keeper enabled
[3]	GPIO4_WK_EN	<ul style="list-style-type: none"> 1'b0: GPIO4 weak keeper disabled (default) 1'b1: GPIO4 weak keeper enabled
[2]	GPIO3_WK_EN	<ul style="list-style-type: none"> 1'b0: GPIO3 weak keeper disabled (default) 1'b1: GPIO3 weak keeper enabled
[1]	GPIO2_WK_EN	<ul style="list-style-type: none"> 1'b0: GPIO2 weak keeper disabled (default) 1'b1: GPIO2 weak keeper enabled
[0]	GPIO1_WK_EN	<ul style="list-style-type: none"> 1'b0: GPIO1 weak keeper disabled (default) 1'b1: GPIO1 weak keeper enabled



Register 87-86: GPIO SDB

Bits	[15:11]	[10]	[9]	[8]	[7]	[6]	[5]	[4]	[3]	[2]	[1]	[0]
Default	5'b00000	1'b0	1'b0	1'b0	1'b0	1'b0	1'b0	1'b0	1'b0	1'b0	1'b0	1'b0

Bits	Mnemonic	Description
[15:11]	RESERVED	NA
[10]	GPIO11_SDB	<ul style="list-style-type: none"> 1'b0: GPIO11 input disabled (default) 1'b1: GPIO11 input enabled
[9]	GPIO10_SDB	<ul style="list-style-type: none"> 1'b0: GPIO10 input disabled (default) 1'b1: GPIO10 input enabled
[8]	GPIO9_SDB	<ul style="list-style-type: none"> 1'b0: GPIO9 input disabled (default) 1'b1: GPIO9 input enabled
[7]	GPIO8_SDB	<ul style="list-style-type: none"> 1'b0: GPIO8 input disabled (default) 1'b1: GPIO8 input enabled
[6]	GPIO7_SDB	<ul style="list-style-type: none"> 1'b0: GPIO7 input disabled (default) 1'b1: GPIO7 input enabled
[5]	GPIO6_SDB	<ul style="list-style-type: none"> 1'b0: GPIO6 input disabled (default) 1'b1: GPIO6 input enabled
[4]	GPIO5_SDB	<ul style="list-style-type: none"> 1'b0: GPIO5 input disabled (default) 1'b1: GPIO5 input enabled
[3]	GPIO4_SDB	<ul style="list-style-type: none"> 1'b0: GPIO4 input disabled (default) 1'b1: GPIO4 input enabled
[2]	GPIO3_SDB	<ul style="list-style-type: none"> 1'b0: GPIO3 input disabled (default) 1'b1: GPIO3 input enabled
[1]	GPIO2_SDB	<ul style="list-style-type: none"> 1'b0: GPIO2 input disabled (default) 1'b1: GPIO2 input enabled
[0]	GPIO1_SDB	<ul style="list-style-type: none"> 1'b0: GPIO1 input disabled (default) 1'b1: GPIO1 input enabled



Register 89-88: GPIO OE

Bits	[15:11]	[10]	[9]	[8]	[7]	[6]	[5]	[4]	[3]	[2]	[1]	[0]
Default	5'b00000	1'b0	1'b0	1'b0	1'b0	1'b0	1'b0	1'b0	1'b0	1'b0	1'b0	1'b0

Bits	Mnemonic	Description
[15:11]	RESERVED	NA
[10]	GPIO11_OE	<ul style="list-style-type: none"> 1'b0: Tristate GPIO11 output (default) 1'b1: GPIO11 output enabled
[9]	GPIO10_OE	<ul style="list-style-type: none"> 1'b0: Tristate GPIO10 output (default) 1'b1: GPIO10 output enabled
[8]	GPIO9_OE	<ul style="list-style-type: none"> 1'b0: Tristate GPIO9 output (default) 1'b1: GPIO9 output enabled
[7]	GPIO8_OE	<ul style="list-style-type: none"> 1'b0: Tristate GPIO8 output (default) 1'b1: GPIO8 output enabled
[6]	GPIO7_OE	<ul style="list-style-type: none"> 1'b0: Tristate GPIO7 output (default) 1'b1: GPIO7 output enabled
[5]	GPIO6_OE	<ul style="list-style-type: none"> 1'b0: Tristate GPIO6 output (default) 1'b1: GPIO6 output enabled
[4]	GPIO5_OE	<ul style="list-style-type: none"> 1'b0: Tristate GPIO5 output (default) 1'b1: GPIO5 output enabled
[3]	GPIO4_OE	<ul style="list-style-type: none"> 1'b0: Tristate GPIO4 output (default) 1'b1: GPIO4 output enabled
[2]	GPIO3_OE	<ul style="list-style-type: none"> 1'b0: Tristate GPIO3 output (default) 1'b1: GPIO3 output enabled
[1]	GPIO2_OE	<ul style="list-style-type: none"> 1'b0: Tristate GPIO2 output (default) 1'b1: GPIO2 output enabled
[0]	GPIO1_OE	<ul style="list-style-type: none"> 1'b0: Tristate GPIO1 output (default) 1'b1: GPIO1 output enabled



Register 91-90: GPIO READ

Bits	[15:11]	[10]	[9]	[8]	[7]	[6]	[5]	[4]	[3]	[2]	[1]	[0]
Default	5'b00000	1'b0	1'b0	1'b0	1'b0	1'b0	1'b0	1'b0	1'b0	1'b0	1'b0	1'b0

Bits	Mnemonic	Description
[15:11]	RESERVED	NA
[10]	GPIO11_READ	<ul style="list-style-type: none"> 1'b0: GPIO11 readback disabled (default) 1'b1: Allows readback of GPIO11 input
[9]	GPIO10_READ	<ul style="list-style-type: none"> 1'b0: GPIO10 readback disabled (default) 1'b1: Allows readback of GPIO10 input
[8]	GPIO9_READ	<ul style="list-style-type: none"> 1'b0: GPIO9 readback disabled (default) 1'b1: Allows readback of GPIO9 input
[7]	GPIO8_READ	<ul style="list-style-type: none"> 1'b0: GPIO8 readback disabled (default) 1'b1: Allows readback of GPIO8 input
[6]	GPIO7_READ	<ul style="list-style-type: none"> 1'b0: GPIO7 readback disabled (default) 1'b1: Allows readback of GPIO7 input
[5]	GPIO6_READ	<ul style="list-style-type: none"> 1'b0: GPIO6 readback disabled (default) 1'b1: Allows readback of GPIO6 input
[4]	GPIO5_READ	<ul style="list-style-type: none"> 1'b0: GPIO5 readback disabled (default) 1'b1: Allows readback of GPIO5 input
[3]	GPIO4_READ	<ul style="list-style-type: none"> 1'b0: GPIO4 readback disabled (default) 1'b1: Allows readback of GPIO4 input
[2]	GPIO3_READ	<ul style="list-style-type: none"> 1'b0: GPIO3 readback disabled (default) 1'b1: Allows readback of GPIO3 input
[1]	GPIO2_READ	<ul style="list-style-type: none"> 1'b0: GPIO2 readback disabled (default) 1'b1: Allows readback of GPIO2 input
[0]	GPIO1_READ	<ul style="list-style-type: none"> 1'b0: GPIO1 readback disabled (default) 1'b1: Allows readback of GPIO1 input

Register 92: PWM1 COUNT

Bits	[7:0]
Default	8'd0

Bits	Mnemonic	Description
[7:0]	PWM1_COUNT	8-bit value to set the number of SYS_CLK periods the PWM signal is high for. Valid from 8'd0 to 8'd255

**Register 94-93: PWM1 FREQUENCY**

Bits	[15:0]
Default	16'd0

Bits	Mnemonic	Description
[15:0]	PWM1_FREQ	<p>16-bit value to set the frequency of the PWM signal in terms of SYS_CLK divisions.</p> <p>Valid from 16'h0000 to 16'hFFFF</p> $\text{frequency (Hz)} = \text{SYS_CLK} / (\text{PWM1_FREQ} + 1)$ $\text{Duty Cycle (\%)} = (1 - (\text{PWM1_FREQ} + 1 - \text{PWM1_COUNT}) / (\text{PWM1_FREQ} + 1)) = (\text{PWM1_COUNT} / (\text{PWM1_FREQ} + 1)) * 100$

Register 95: PWM2 COUNT

Bits	[7:0]
Default	8'd0

Bits	Mnemonic	Description
[7:0]	PWM2_COUNT	<p>8-bit value to set the number of SYS_CLK periods the PWM signal is high for.</p> <p>Valid from 8'd0 to 8'd255</p>

Register 97-96: PWM2 FREQUENCY

Bits	[15:0]
Default	16'd0

Bits	Mnemonic	Description
[15:0]	PWM2_FREQ	<p>16-bit value to set the frequency of the PWM signal in terms of SYS_CLK divisions.</p> <p>Valid from 16'h0000 to 16'hFFFF</p> $\text{frequency (Hz)} = \text{SYS_CLK} / (\text{PWM2_FREQ} + 1)$ $\text{Duty Cycle (\%)} = (1 - (\text{PWM2_FREQ} + 1 - \text{PWM2_COUNT}) / (\text{PWM2_FREQ} + 1)) = (\text{PWM2_COUNT} / (\text{PWM2_FREQ} + 1)) * 100$

Register 98: PWM3 COUNT

Bits	[7:0]
Default	8'd0

Bits	Mnemonic	Description
[7:0]	PWM3_COUNT	<p>8-bit value to set the number of SYS_CLK periods the PWM signal is high for.</p> <p>Valid from 8'd0 to 8'd255</p>

Register 100-99: PWM3 FREQUENCY

ES9822 PRO Product Datasheet



Bits	[15:0]
Default	16'd0

Bits	Mnemonic	Description
[15:0]	PWM3_FREQ	<p>16-bit value to set the frequency of the PWM signal in terms of SYS_CLK divisions.</p> <p>Valid from 16'h0000 to 16'hFFFF</p> <p>frequency (Hz)=SYS_CLK/(PWM3_FREQ+1)</p> <p>Duty Cycle (%) = $(1-(PWM3_COUNT)/(PWM3_FREQ+1)) \times 100$</p>



ADC CH1 Registers

Register 101: ADC CH1 DATAPATH CONTROL

Bits	[7]	[6]	[5:3]	[2]	[1]	[0]
Default	1'b0	1'b0	3'b000	1'b0	1'b0	1'b0

Bits	Mnemonic	Description
[7]	ADC1_BYPASS_FIR2X	<ul style="list-style-type: none"> 1'b0: Non-bypass (default) 1'b1: Bypass DFir_2x
[6]	ADC1_BYPASS_FIR4X	<ul style="list-style-type: none"> 1'b0: Non-bypass (default) 1'b1: Bypass DFir_4x
[5:3]	RESERVED	NA
[2]	ADC1_ENABLE_DC_BLOCKING	Enables DC blocking path. <ul style="list-style-type: none"> 1'b0: Disabled (default)
[1]	RESERVED	NA
[0]	ADC1_NEG_SEL	Negates data input from analog ADC. <ul style="list-style-type: none"> 1'b0: No negation (default) 1'b1: Negates input data

Register 102: ADC CH1 THD COMP CONFIG

Bits	[7:2]	[1]	[0]
Default	6'd0	1'b0	1'b0

Bits	Mnemonic	Description
[7:2]	ADC1_CORRECTION_ADDR	Selects the address when writing the THD compensation RAM.
[1]	ADC1_CORRECTION_WE	Enables writing to the THD compensation RAM. <ul style="list-style-type: none"> 1'b0: Writing disabled (default) 1'b1: Writing enabled
[0]	ADC1_ENABLE_THD_COMP	Selects whether THD compensation is enabled and used in the signal path or disabled and bypassed. <ul style="list-style-type: none"> 1'b0: THD compensation is disabled and bypassed (default) 1'b1: THD compensation is enabled. Data is processed by THD compensation

Register 104-103: ADC CH1 THD COMP DATA

Bits	[15:0]
Default	16'd0

Bits	Mnemonic	Description
[15:0]	ADC1_CORRECTION_DATA	A 16 bits THD corrected value that will be written to the address of the THD compensation RAM. Maximum -42dB (16'hFFFF).

Register 105: ADC CH1 PEAK DETECTOR CONFIG



Bits	[7]	[6:2]	[1]	[0]
Default	-	5'd0	1'b0	1'b0

Bits	Mnemonic	Description
[7]	ADC1_LOCK_PEAK	Locks the stored value of the peak detector for reading back. <ul style="list-style-type: none"> 1'b0: Stored value is allowed to update (default) 1'b1: Stored value is locked
[6:2]	ADC1_DECAY_RATE	Sets the speed at which the stored value of the peak detector will decay when the input signal is below the stored value. <ul style="list-style-type: none"> 5'd63 = Slowest decay 5'd0 = Instant decay (default)
[1]	RESERVED	NA
[0]	ADC1_ENABLE_PEAK_DETECT	Enables the ADC signal peak detector. <ul style="list-style-type: none"> 1'b0: Disabled (default) 1'b1: Enabled

Register 106: ADC CH1 PEAK DETECTOR LEVEL

Bits	[7:0]
Default	8'hFF

Bits	Mnemonic	Description
[7:0]	ADC1_CLIP_LEVEL	Threshold value of the clip detector. Valid from 8'hff (0dB) to 8'h01 (-42dB).

Register 108-107: ADC CH1 DC OFFSET

Bits	[15:0]
Default	16'd0

Bits	Mnemonic	Description
[15:0]	ADC1_DC_OFFSET	ADC DC offset. Signed. Shift right 1 bit corresponds to -6dB. Positive offset is valid from 16'h7FFF (-30dB) to 16'h0001 (-114dB). Negative offset is valid from 16'h8000 (-30dB) to 16'hFFFF (-114dB). 16'h0000 corresponds to zero offset.

**Register 110-109: ADC CH1 VOLUME**

Bits	[15:0]
Default	16'h7FFF

Bits	Mnemonic	Description
[15:0]	ADC1_VOLUME	Next desired ADC volume coefficient. Signed. Shift right 1 bit corresponds to -6dB. Valid from 16'h7FFF (0dB) (default) to 16'h0001 (-84dB). 16'd0 corresponds to mute.

Register 111: ADC CH1 VOLUME RATE

Bits	[7:0]
Default	8'd0

Bits	Mnemonic	Description
[7:0]	ADC1_VOLUME_RATE	Value by which the old coefficient value is incremented/decremented to reach the new coefficient. Valid from 8'd0 (instant) to 8'd255 (fastest), where 8'd1 is the slowest ramp_rate.

Register 112: ADC CH1 SCALE AND IIR BANDWIDTH

Bits	[7:2]	[1:0]
Default	6'd8	2'd0

Bits	Mnemonic	Description
[7:2]	RESERVED	NA
[1:0]	ADC1_DATA_SCALE	ADC data scale. <ul style="list-style-type: none"> 2'd0: 0dB 2'd1: 6dB 2'd2: 12dB 2'd3: 18dB



Register 113: ADC CH1 PROG FILTER AND IIR BANDWIDTH

Bits	[7:5]	[4:2]	[1]	[0]
Default	3'd4	3'd0	1'b0	1'b0

Bits	Mnemonic	Description
[7:5]	RESERVED	NA
[4:2]	ADC1_FILTER_SHAPE	Selects the 8x decimation FIR filter shape. <ul style="list-style-type: none"> 3'd0: Minimum phase (default) 3'd1: Linear phase apodizing 3'd2: Linear phase fast roll-off 3'd3: Linear phase fast roll-off low ripple 3'd4: Linear phase slow roll-off 3'd5: Minimum phase fast roll-off 3'd6: Minimum phase slow roll-off 3'd7: Minimum phase slow roll-off low dispersion
[1]	ADC1_PROG_COEFF_WRITE_EN	Enables writing to the programmable coefficient RAM. <ul style="list-style-type: none"> 1'b0: Disables write signal to the coefficient RAM (default) 1'b1: Enables write signal to the coefficient RAM.
[0]	ADC1_PROG_COEFF_EN	Enables the custom decimation filter coefficients. <ul style="list-style-type: none"> 1'b0: Uses a built-in filter selected by FILTER_SHAPE (default) 1'b1: Uses the coefficients programmed via PROG_COEFF_IN

Register 114: ADC CH1 PROG FILTER COEFF ADDR

Bits	[7]	[6:0]
Default	1'b0	7'd0

Bits	Mnemonic	Description
[7]	ADC1_PROG_COEFF_STAGE	Selects which stage of the filter to write. <ul style="list-style-type: none"> 1'b0: Selects stage 1 of the decimation filter DFir_4x (default) 1'b1: Selects stage 2 of the decimation filter DFir_2x
[6:0]	ADC1_PROG_COEFF_ADDR	Selects the coefficient address when writing custom coefficients for the decimation filter.

Register 117-115: ADC CH1 PROG FILTER COEFF

Bits	[23:0]
Default	24'd0

Bits	Mnemonic	Description
[23:0]	ADC1_PROG_COEFF_IN	A 24bit signed filter coefficient that will be written to the address defined in PROG_COEFF_ADDR.



ADC CH2 Registers

Register 118: ADC CH2 DATAPATH CONTROL

Bits	[7]	[6]	[5:3]	[2]	[1]	[0]
Default	1'b0	1'b0	3'b000	1'b0	1'b0	1'b0

Bits	Mnemonic	Description
[7]	ADC2_BYPASS_FIR2X	<ul style="list-style-type: none"> 1'b0: Non-bypass (default) 1'b1: Bypass DFir_2x
[6]	ADC2_BYPASS_FIR4X	<ul style="list-style-type: none"> 1'b0: Non-bypass (default) 1'b1: Bypass DFir_4x
[5:3]	RESERVED	NA
[2]	ADC2_ENABLE_DC_BLOCKING	Enables DC blocking path. <ul style="list-style-type: none"> 1'b0: Disabled (default) 1'b1: Enabled
[1]	RESERVED	NA
[0]	ADC2_NEG_SEL	Negates data input from analog ADC. <ul style="list-style-type: none"> 1'b0: No negation (default) 1'b1: Negates input data

Register 119: ADC CH2 THD COMP CONFIG

Bits	[7:2]	[1]	[0]
Default	6'd0	1'b0	1'b0

Bits	Mnemonic	Description
[7:2]	ADC2_CORRECTION_ADDR	Selects the address when writing the THD compensation RAM.
[1]	ADC2_CORRECTION_WE	Enables writing to the THD compensation RAM. <ul style="list-style-type: none"> 1'b0: Writing disabled (default) 1'b1: Writing enabled
[0]	ADC2_ENABLE_THD_COMP	Selects whether THD compensation is enabled and used in the signal path, or disabled and bypassed. <ul style="list-style-type: none"> 1'b0: THD compensation is disabled and bypassed (default) 1'b1: THD compensation is enabled. Data is processed by THD compensation

Register 121-120: ADC CH2 THD COMP DATA

Bits	[15:0]
Default	16'd0

Bits	Mnemonic	Description
[15:0]	ADC2_CORRECTION_DATA	A 16 bits THD corrected value that will be written to the address of the THD compensation RAM. Maximum -42dB (16'hFFFF).

**Register 122: ADC CH2 PEAK DETECTOR CONFIG**

Bits	[7]	[6:2]	[1]	[0]
Default	-	5'd0	1'b0	1'b0

Bits	Mnemonic	Description
[7]	ADC2_LOCK_PEAK	Locks the stored value of the peak detector for reading back. <ul style="list-style-type: none"> 1'b0: Stored value is allowed to update (default) 1'b1: Stored value is locked
[6:2]	ADC2_DECAY_RATE	Sets the speed at which the stored value of the peak detector will decay when the input signal is below the stored value. <ul style="list-style-type: none"> 5'd63 = Slowest decay 5'd0 = Instant decay (default)
[1]	RESERVED	NA
[0]	ADC2_ENABLE_PEAK_DETECT	Enables the ADC signal peak detector. <ul style="list-style-type: none"> 1'b0: Disabled (default) 1'b1: Enabled

Register 123: ADC CH2 PEAK DETECTOR LEVEL

Bits	[7:0]
Default	8'hFF

Bits	Mnemonic	Description
[7:0]	ADC2_CLIP_LEVEL	Threshold value of the clip detector. Valid from 8'hff (0dB) to 8'h01 (-42dB).

Register 125-124: ADC CH2 DC OFFSET

Bits	[15:0]
Default	16'd0

Bits	Mnemonic	Description
[15:0]	ADC2_DC_OFFSET	ADC DC offset. Signed. Shift right 1 bit corresponds to -6dB. Positive offset is valid from 16'h7FFF (-30dB) to 16'h0001 (-114dB). Negative offset is valid from 16'h8000 (-30dB) to 16'hFFFF (-114dB). 16'h0000 corresponds to zero offset.

**Register 127-126: ADC CH2 VOLUME**

Bits	[15:0]
Default	16'h7FFF

Bits	Mnemonic	Description
[15:0]	ADC2_VOLUME	Next desired ADC volume coefficient. Signed. Shift right 1 bit corresponds to -6dB. Valid from 16'h7FFF (0dB) (default) to 16'h0001 (-84dB). 16'd0 corresponds to mute.

Register 128: ADC CH2 VOLUME RATE

Bits	[7:0]
Default	8'd0

Bits	Mnemonic	Description
[7:0]	ADC2_VOLUME_RATE	Value by which the old coefficient value is incremented/decremented to reach the new coefficient. Valid from 8'd0 (instant) to 8'd255 (fastest), where 8'd1 is the slowest ramp_rate.

Register 129: ADC CH2 SCALE AND IIR BANDWIDTH

Bits	[7:2]	[1:0]
Default	6'd8	2'd0

Bits	Mnemonic	Description
[7:2]	RESERVED	NA
[1:0]	ADC2_DATA_SCALE	ADC data scale. <ul style="list-style-type: none"> • 2'd0: 0dB • 2'd1: 6dB • 2'd2: 12dB • 2'd3: 18dB



Register 130: ADC CH2 PROG FILTER AND IIR BANDWIDTH

Bits	[7:5]	[4:2]	[1]	[0]
Default	3'd4	3'd0	1'b0	1'b0

Bits	Mnemonic	Description
[7:5]	RESERVED	NA
[4:2]	ADC2_FILTER_SHAPE	Selects the 8x decimation FIR filter shape. <ul style="list-style-type: none"> 3'd0: Minimum phase (default) 3'd1: Linear phase apodizing 3'd2: Linear phase fast roll-off 3'd3: Linear phase fast roll-off low ripple 3'd4: Linear phase slow roll-off 3'd5: Minimum phase fast roll-off 3'd6: Minimum phase slow roll-off 3'd7: Minimum phase slow roll-off low dispersion
[1]	ADC2_PROG_COEFF_WRITE_EN	Enables writing to the programmable coefficient RAM. <ul style="list-style-type: none"> 1'b0: Disables write signal to the coefficient RAM (default) 1'b1: Enables write signal to the coefficient RAM.
[0]	ADC2_PROG_COEFF_EN	Enables the custom decimation filter coefficients. <ul style="list-style-type: none"> 1'b0: Uses a built-in filter selected by FILTER_SHAPE (default) 1'b1: Uses the coefficients programmed via PROG_COEFF_IN

Register 131: ADC CH2 PROG FILTER COEFF ADDR

Bits	[7]	[6:0]
Default	1'b0	7'd0

Bits	Mnemonic	Description
[7]	ADC2_PROG_COEFF_STAGE	Selects which stage of the filter to write. <ul style="list-style-type: none"> 1'b0: Selects stage 1 of the decimation filter DFir_4x (default) 1'b1: Selects stage 2 of the decimation filter DFir_2x
[6:0]	ADC2_PROG_COEFF_ADDR	Selects the coefficient address when writing custom coefficients for the decimation filter.

**Register 134-132: ADC CH2 PROG FILTER COEFF**

Bits	[23:0]
Default	24'd0

Bits	Mnemonic	Description
[23:0]	ADC2_PROG_COEFF_IN	A 24bit signed filter coefficient that will be written to the address defined in PROG_COEFF_ADDR.

Register 135: ADC CH1B DATAPATH CONTROL

Bits	[7:1]	[0]
Default	7'd0	1'b0

Bits	Mnemonic	Description
[7:1]	RESERVED	NA
[0]	ADC1B_NEG_SEL	Negates data input from analog ADC. <ul style="list-style-type: none"> 1'b0: No negation (default) 1'b1: Negates input data

Register 136-151: RESERVED**Register 152: ADC CH2B DATAPATH CONTROL**

Bits	[7:1]	[0]
Default	7'd0	1'b0

Bits	Mnemonic	Description
[7:1]	RESERVED	NA
[0]	ADC2B_NEG_SEL	Negates data input from analog ADC. <ul style="list-style-type: none"> 1'b0: No negation (default) 1'b1: Negates input data



Synchronous Slave Interface Registers

Register 192: SOFT RESET

Bits	[7]	[6:0]
Default	1'b0	7'd0

Bits	Mnemonic	Description
[7]	AO_SOFT_RESET	Performs soft reset to digital core except for the PLL REGISTERS.
[6:0]	RESERVED	NA

Register 193: CLK SELECT

Bits	[7:3]	[2:1]	[0]
Default	5'd0	2'd0	1'b0

Bits	Mnemonic	Description
[7:3]	RESERVED	NA
[2:1]	SEL_SYSCLK_IN	Selects digital core and ADC clock source when EN_ANA_CLKIN is set. <ul style="list-style-type: none"> 2'd0: XTAL (default) 2'd1: MCLK 2'd2: ACLK 2'd3: PLL
[0]	EN_ANA_CLKIN	Enables clock outputs to the digital core and ADC. <ul style="list-style-type: none"> 1'b0: Disabled (default) 1'b1: Enabled

Register 194: ADC CLOCK DIVIDE

Bits	[7:2]	[1:0]
Default	6'd0	2'd0

Bits	Mnemonic	Description
[7:2]	RESERVED	NA
[1:0]	SEL_CLK_DIV	Sets ADC clock rate: <ul style="list-style-type: none"> 2'd0: full-rate (Divide by 1) 2'd1: 1/2 rate (Divide by 2) 2'd2: 1/4 rate (Divide by 4) 2'd3: 1/8 rate (Divide by 8)

Register 203-195: RESERVED



System Readback Registers

Register 224: READ SYSTEM REGISTER 0

Bits	[7:4]	[3]	[2]	[1]	[0]
Default	-	-	-	-	-

Bits	Mnemonic	Description
[7:4]	RESERVED	NA
[3]	MODE	Readback mode pin
[2]	ADDR2	Readback ADDR2 pin
[1]	ADDR1	Readback ADDR1 pin
[0]	RESERVED	NA

Register 225: CHIP ID

Bits	[7:0]
Default	-

Bits	Mnemonic	Description
[7:0]	CHIP_ID	Chip ID

Register 228-227: RESERVED

Register 229: CLIP FLAG

Bits	[7:2]	[1]	[0]
Default	-	-	-

Bits	Mnemonic	Description
[7:2]	RESERVED	NA
[1]	CLIP_FLAG_CH2	ADC CH2 clip detection flag
[0]	CLIP_FLAG_CH1	ADC CH1 clip detection flag

Register 230: RESERVED

Register 231: READ SYSTEM REGISTER 5

Bits	[7]	[6]	[5]	[4]	[3:0]
Default	-	-	-	-	-

Bits	Mnemonic	Description
[7]	ASP2_INIT_DONE	ASP2 initialize is done
[6]	ASP1_INIT_DONE	ASP1 initialize is done
[5]	RESERVED	NA
[4]	TDM_VALID	TDM valid flag
[3:0]	RESERVED	NA



GPIO READBACK REGISTERS

Register 233-232: GPIO READBACK REGISTERS

Bits	[15:11]	[10]	[9]	[8]	[7]	[6]	[5]	[4]	[3]	[2]	[1]	[0]
Default	-	-	-	-	-	-	-	-	-	-	-	-

Bits	Mnemonic	Description
[15:11]	RESERVED	NA
[10]	GPIO11_READBACK	GPIO 11 Readback
[9]	GPIO10_READBACK	GPIO 10 Readback
[8]	GPIO9_READBACK	GPIO 9 Readback
[7]	GPIO8_READBACK	GPIO 8 Readback
[6]	GPIO7_READBACK	GPIO 7 Readback
[5]	GPIO6_READBACK	GPIO 6 Readback
[4]	GPIO5_READBACK	GPIO 5 Readback
[3]	GPIO4_READBACK	GPIO 4 Readback
[2]	GPIO3_READBACK	GPIO 3 Readback
[1]	GPIO2_READBACK	GPIO 2 Readback
[0]	GPIO1_READBACK	GPIO 1 Readback



ADC CH1 READBACK Registers

Register 236-234: PROG COEFF OUT

Bits	[23:0]
Default	-

Bits	Mnemonic	Description
[23:0]	ADC1_PROG_COEFF_OUT	Programmable FIR coeff readback

Register 238-237: PEAK

Bits	[15:0]
Default	-

Bits	Mnemonic	Description
[15:0]	ADC1_PEAK	Detected peak value readback



ADC CH2 Readback Registers

Register 241-239: PROG COEFF OUT

Bits	[23:0]
Default	-

Bits	Mnemonic	Description
[23:0]	ADC2_PROG_COEFF_OUT	Programmable FIR coeff readback

Register 243-242: PEAK

Bits	[15:0]
Default	-

Bits	Mnemonic	Description
[15:0]	ADC2_PEAK	Detected peak value readback



ES9822 PRO Reference Schematic

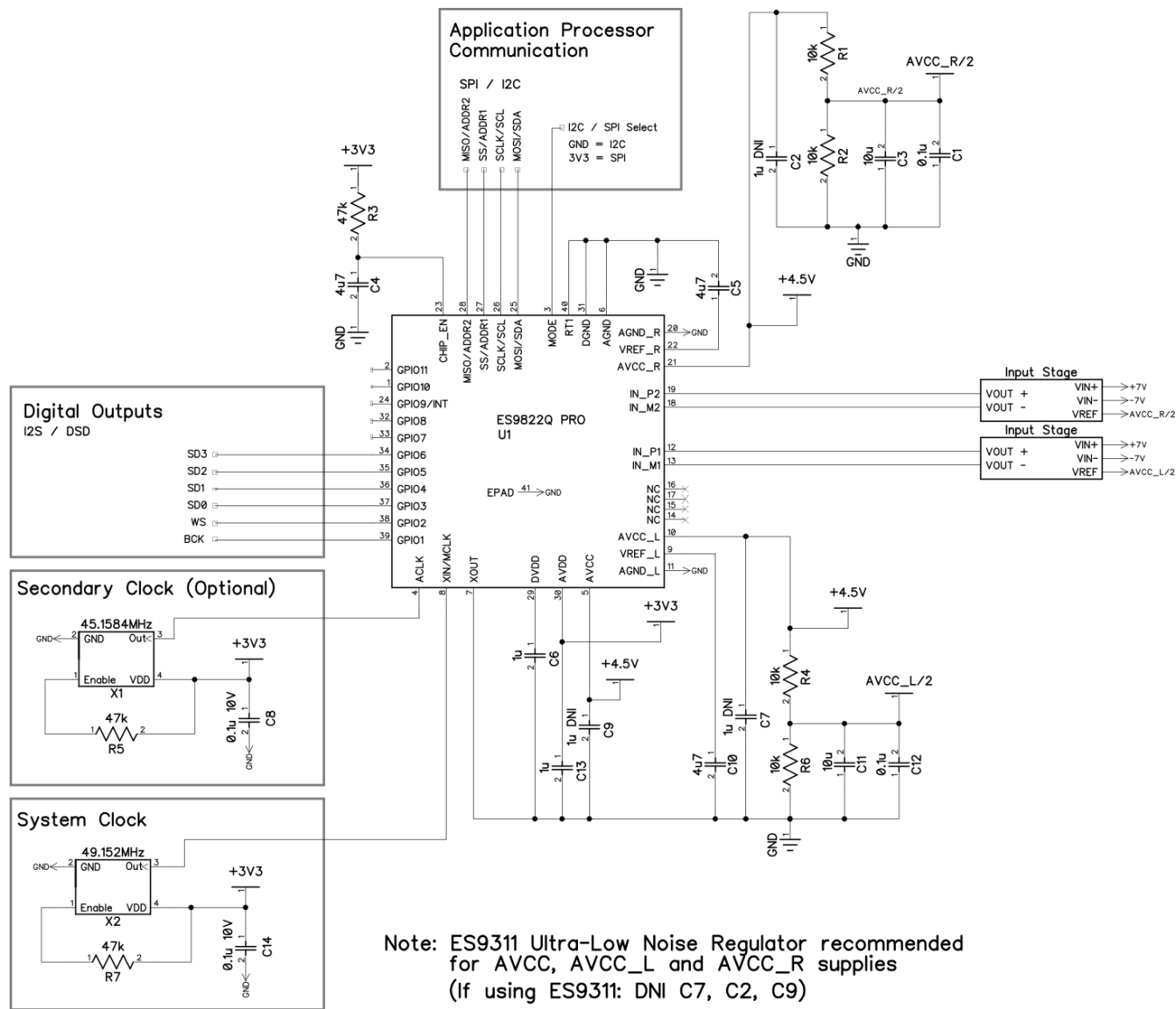
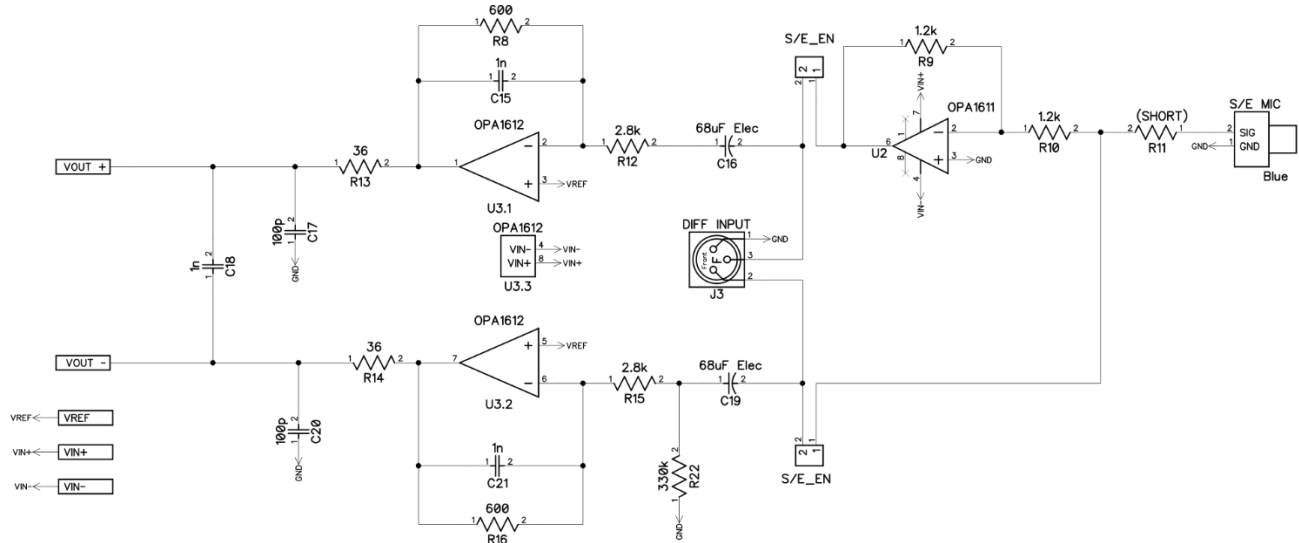

Figure 8 - ES9822QPRO Reference schematic for normal operation

Schematic subject to change

Note 1: Pin 41 QFN Package Pad (EPAD) should be connected to DGND



Note: All resistors are thin-film and all caps are COG/NPO unless otherwise specified

Figure 9 - Reference schematic ADC input stage for Single Ended (S/E) and differential input

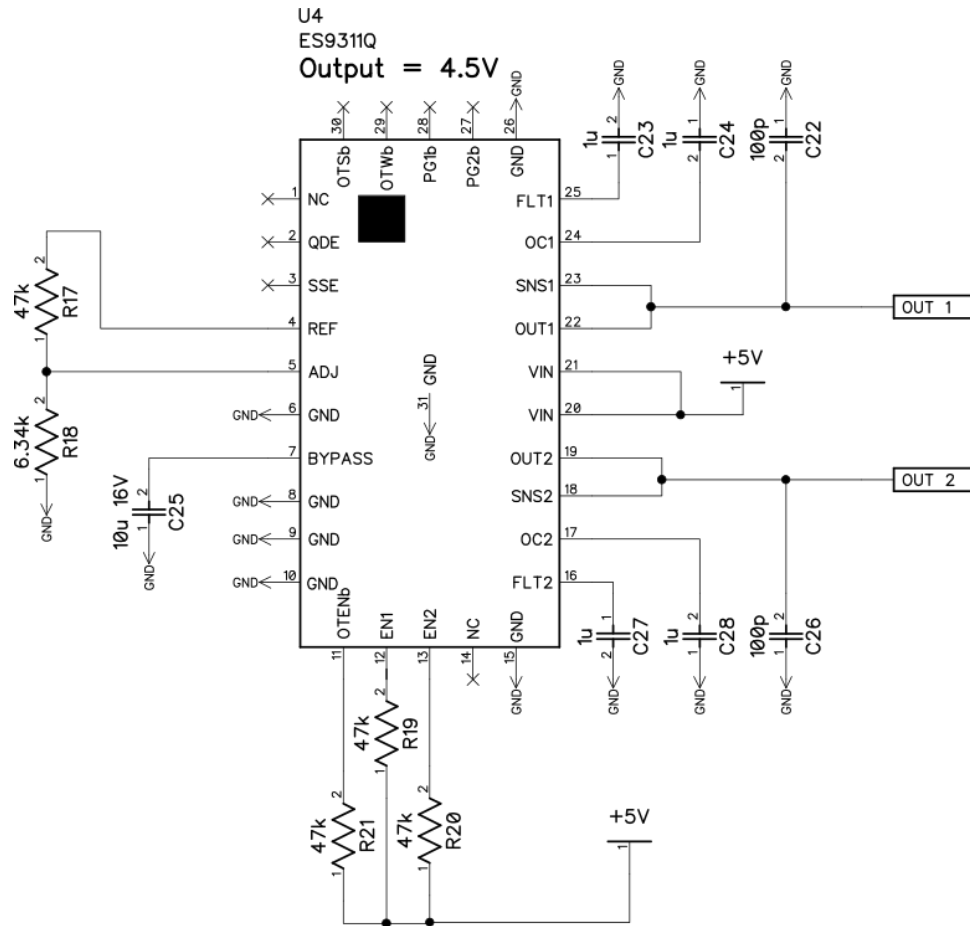

Figure 10 - ES9311Q Reference voltage regulator schematic



Internal Pad Circuitry

Pin	Type	Pin Name	Equivalent Circuit
AVCC AVCC_L AVCC_R DVDD AVDD	Power (Positive)	5 10 21 29 30	
AGND AGND_L AGND_R DGND	Ground	6 11 20 31	
23	Reset	CHIP_EN	
GPIO10 GPIO11 MODE ACLK GPIO9/INT MOSI/SDA SCLK/SCL SS/ADDR1 MISO/ADDR2 GPIO8 GPIO7 GPIO6	Digital I/O	1 2 3 4 24 25 26 27 28 32 33 34	



GPIO5		35	
GPIO4		36	
GPIO3		37	
GPIO2		38	
GPIO1		39	
RT1		40	
XOUT	Analog IO	7	
XIN		8	
VREF_L		9	
IN_P1		12	
IN_M1		13	
IN_M2		18	
IN_P2		19	
VREF_R	22		

Table 27 - Internal Pad Circuitry



40 QFN Package Dimensions

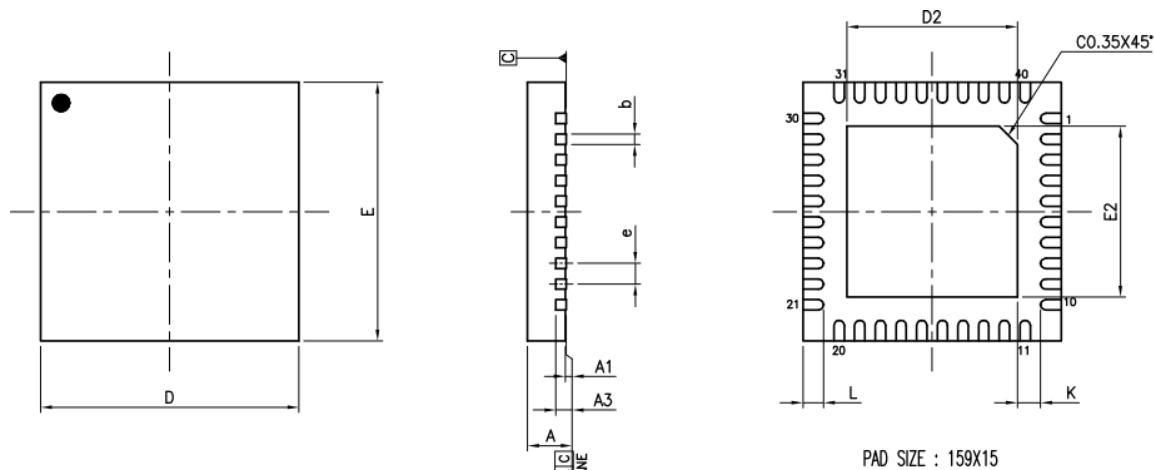

PACKAGE TYPE			
JEDEC OUTLINE	MO-220		
PKG CODE	WQFN(X540)		
SYMBOLS	MIN.	NOM.	MAX.
A	0.70	0.75	0.80
A1	0.00	0.02	0.05
A3	0.203 REF.		
b	0.15	0.20	0.25
D	5.00 BSC		
E	5.00 BSC		
e	0.40 BSC		
K	0.20	-	-

PAD SIZE : 159X15

NOTES :

1. ALL DIMENSIONS ARE IN MILLIMETERS.
2. DIMENSION b APPLIES TO METALLIZED TERMINAL AND IS MEASURED BETWEEN 0.15mm AND 0.30mm FROM THE TERMINAL TIP. IF THE TERMINAL HAS THE OPTIONAL RADIUS ON THE OTHER END OF THE TERMINAL, THE DIMENSION b SHOULD NOT BE MEASURED IN THAT RADIUS AREA.
3. BILATERAL COPLANARITY ZONE APPLIES TO THE EXPOSED HEAT SINK SLUG AS WELL AS THE TERMINALS.

PAD SIZE	D2			E2			L		
	MIN.	NOM.	MAX.	MIN.	NOM.	MAX.	MIN.	NOM.	MAX.
159X15* MIL	3.74	3.79	3.84	3.74	3.79	3.84	0.25	0.30	0.35

Figure 11 - 40 QFN Package Dimensions



40 QFN Top View Marking

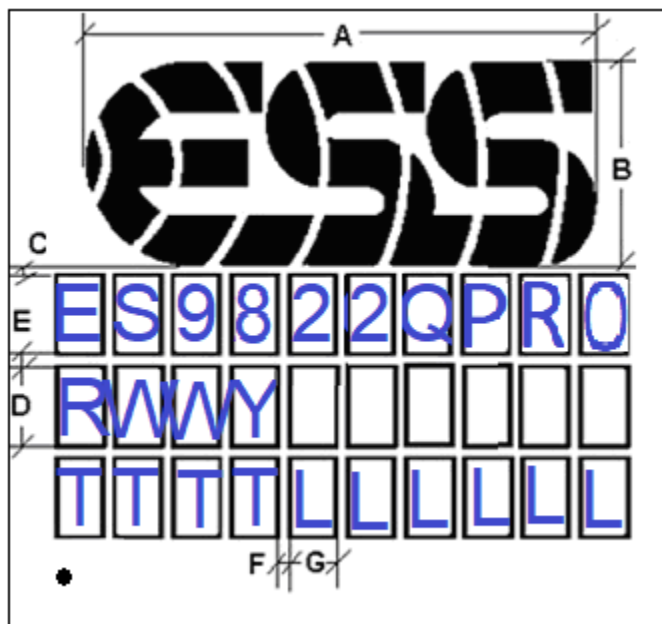

Package Type	Dimension in mm						
	A	B	C	D	E	F	G
QFN 5mm x 5mm	4.0	1.6	0.2	0.4	0.2	0.1	0.3

T	Tracking number
W	Work week
Y	Last digit of year
L	Lot number
R	Silicon Revision

Marking is subject to change. This drawing is not to scale.

Figure 12 - ES9822 PRO QFN Marking



Reflow Process Considerations

Temperature Controlled

For lead-free soldering, the characterization and optimization of the reflow process is the most important factor to consider.

The lead-free alloy solder has a melting point of 217°C. This alloy requires a minimum reflow temperature of 235°C to ensure good wetting. The maximum reflow temperature is in the 245°C to 260°C range, depending on the package size (

RPC-2 Pb-Free Process – Classification Temperatures (T_c). This narrows the process window for lead-free soldering to 10°C to 20°C.

The increase in peak reflow temperature in combination with the narrow process window makes the development of an optimal reflow profile a critical factor for ensuring a successful lead-free assembly process. The major factors contributing to the development of an optimal thermal profile are the size and weight of the assembly, the density of the components, the mix of large and small components, and the paste chemistry being used.

Reflow profiling needs to be performed by attaching calibrated thermocouples well adhered to the device as well as other critical locations on the board to ensure that all components are heated to temperatures above the minimum reflow temperatures and that smaller components do not exceed the maximum temperature limits (Table RPC-2).

To ensure that all packages can be successfully and reliably assembled, the reflow profiles studied and recommended by ESS are based on the JEDEC/IPC standard J-STD-020 revision D.1.

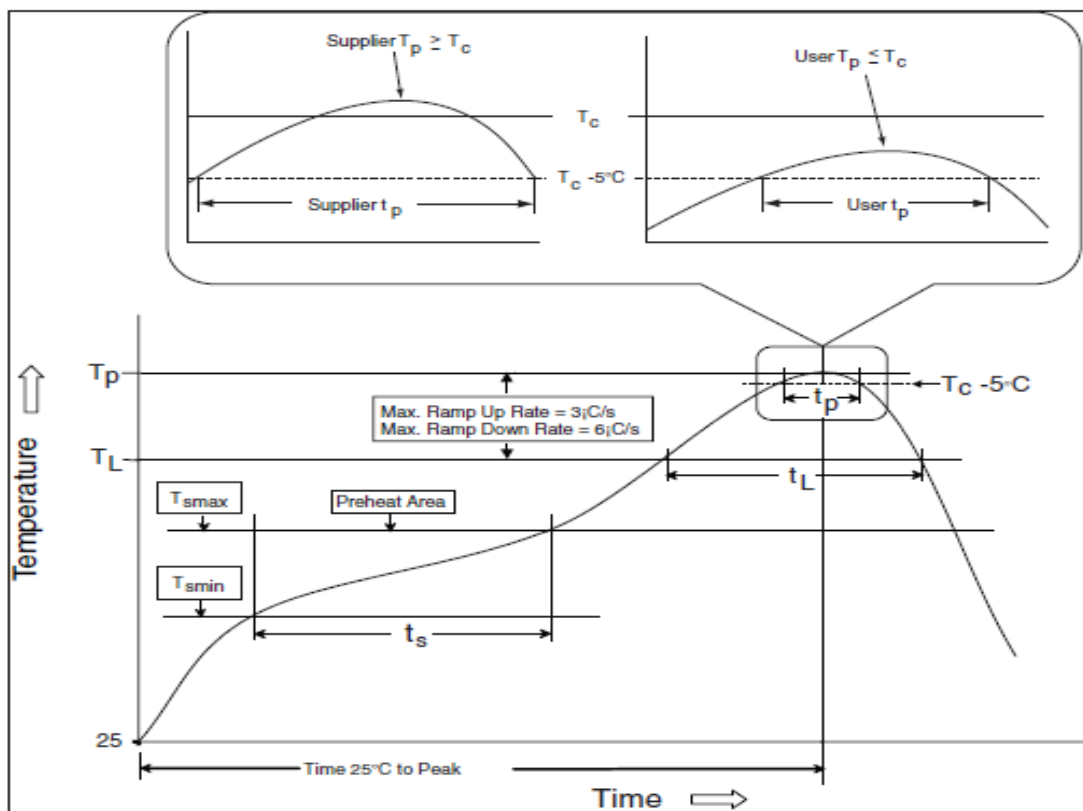

Figure 13 - IR/Convection Reflow Profile (IPC/JEDEC J-STD-020D.1)

Reflow is allowed 3 times. Caution must be taken to ensure time between re-flow runs does not exceed the allowed time by the moisture sensitivity label. If the time elapsed between the re-flows exceeds the moisture sensitivity time bake the board according to the moisture sensitivity label instructions.

Manual

Allowed up to 2 times with maximum temperature of 350°C no longer than 3 seconds.

RPC-1 Classification reflow profile

Profile Feature	Pb-Free Assembly
Preheat/Soak Temperature Min (Tsmmin)	150°C



Temperature Max (T _{max})	200°C
Time (t _s) from (T _{min} to T _{max})	60-120 seconds
Ramp-up rate (T _L to T _p)	3°C / second maximum
Liquidous temperature (T _L)	217°C
Time (t _L) maintained above T _L	60-150 seconds
Peak package body temperature (T _p)	For users T _p must not exceed the classification temp in Table RPC-2. For suppliers T _p must equal or exceed the Classification temp in Table RPC-2.
Time (t _p)* within 5°C of the specified classification temperature (T _c), see Error! Reference source not found.	30* seconds
Ramp-down rate (T _p to T _L)	6°C / second maximum
Time 25°C to peak temperature	8 minutes maximum
* Tolerance for peak profile temperature (T _p) is defined as a supplier minimum and a user maximum.	

Table 28 - RPC-1 Classification reflow profile

All temperatures refer to the center of the package, measured on the package body surface that is facing up during assembly reflow (e.g., live-bug). If parts are reflowed in other than the normal live-bug assembly reflow orientation (i.e., dead-bug), T_p shall be within ±2°C of the live-bug T_p and still meet the T_c requirements, otherwise, the profile shall be adjusted to achieve the latter. To accurately measure actual peak package body temperatures, refer to JEP140 for recommended thermocouple use.

Reflow profiles in this document are for classification/preconditioning and are not meant to specify board assembly profiles. Actual board assembly profiles should be developed based on specific process needs and board designs and should not exceed the parameters in Table RPC-1.

For example, if T_c is 260°C and time t_p is 30 seconds, this means the following for the supplier and the user.

For a supplier: The peak temperature must be at least 260°C. The time above 255°C must be at least 30 seconds.

For a user: The peak temperature must not exceed 260°C. The time above 255°C must not exceed 30 seconds.

All components in the test load shall meet the classification profile requirements.



RPC-2 Pb-Free Process – Classification Temperatures (Tc)

Package Thickness	Volume mm ³ , <350	Volume mm ³ , 350 to 2000	Volume mm ³ , >2000
<1.6 mm	260°C	260°C	260°C
1.6 mm – 2.5 mm	260°C	250°C	245°C
>2.5 mm	250°C	245°C	245°C

Table 29 - RPC-2 Pb-Free Process

At the discretion of the device manufacturer, but not the board assembler/user, the maximum peak package body temperature (Tp) can exceed the values specified in Table RPC-2. The use of a higher Tp does not change the classification temperature (Tc).

Package volume excludes external terminals (e.g., balls, bumps, lands, leads) and/or nonintegral heat sinks.

The maximum component temperature reached during reflow depends on package thickness and volume. The use of convection reflow processes reduces the thermal gradients between packages. However, thermal gradients due to differences in thermal mass of SMD packages may still exist.



Ordering Information

Part Number	Description	Package
ES9822QPRO	SABRE 32-bit 2 Channel ADC with Built in programmable filters, ASP, and multiple output format	5mm x 5mm 40 QFN

Table 30 - Ordering Information



Addendum

The following subsections outline the recommended configuration for Common I2S and TDM modes in s2m format.

I2S Master

FS=48kHz, 2 Channel, MCLK=49.152MHz

```
w 0x48 193 0x01; //SEL_SYSCLK_IN = 00 (XTAL), EN_ANA_CLKIN = 1
//w 0x48 193 0x05; //SEL_SYSCLK_IN = 10 (ACLK), EN_ANA_CLKIN = 1
w 0x48 194 0x01; //SEL_CLK_DIV = 1/2 (for 49.152/45.1584MHz, this sets ADC clock rate, must be 22
or 24MHz)

w 0 0x00; //OUTPUT_SEL = 00 (I2S)
w 1 0x33; //ENABLE_ADC_CH and ENABLE_DATA_IN_CH
w 2 0x07; //SELECT_ADC_NUM = 7 for 48k/44.1k, 3 for 96k, 1 for 192k
w 3 0x01; //SELECT_IADC_NUM = 1, should match SEL_CLK_DIV
w 8 0x07; //MASTER_BCK_DIV1 = 0, MASTER_MODE_ENABLE = 1
w 9 0x07; //SELECT_I2S_TDM_NUM = 7 for 48k/44.1k, 3 for 96k, 1 for 192k (must match Reg 2)
w 10 0x05; //TDM_VALID_EDGE = 1, ENABLE_TDM_CLK = 1
w 11 0x01; //TDM_CH_NUM = 1 (# of channels = 1 + TDM_CH_NUM)
w 12 0x00; //TDM_LINE_SEL_CH1: 00 (GPIO3), TDM_SLOT_SEL_CH1: 0 (slot 0)
w 13 0x01; //TDM_LINE_SEL_CH2: 00 (GPIO3), TDM_SLOT_SEL_CH2: 1 (slot 1)
w 23 0x0A; //FS_PHASE = 10

//GPIO enabling
w 74 0x22; //GPIO1_CFG and GPIO2_CFG set to AUX output (clocks out)
w 75 0x02; //GPIO3_CFG set to AUX output (data out)
w 86 0x03; //GPIO1_SDB and GPIO2_SDB input enabled
w 88 0x07; //GPIO1_OE and GPIO2_OE and GPIO3_OE output enabled

//ADC CONFIG
w 63 0xBB; //adc ch1a config
w 64 0x38;
w 65 0xBB; //adc ch2a config
w 66 0x38;
w 67 0xBB; //adc ch1b config
w 68 0x38;
w 69 0xBB; //adc ch2b config
w 70 0x38;
w 71 0xFF; //set common mode to 3

//ADC filter and datapath registers
w 113 0x98; //ADC1A_FILTER_SHAPE = Minimum phase slow roll off
```



```
w 118 0x01;  
w 130 0x98; //ADC2A_FILTER_SHAPE = Minimum phase slow roll off  
w 135 0x01;  
w 147 0x98; //ADC1B_FILTER_SHAPE = Minimum phase slow roll off  
w 164 0x98; //ADC2B_FILTER_SHAPE = Minimum phase slow roll off
```



I2S Slave

FS=48kHz, 2 Channel, MCLK=49.152MHz

```

w 0x48 193 0x01; //SEL_SYSCLK_IN = 00 (XTAL), EN_ANA_CLKIN = 1
//w 0x48 193 0x05; //SEL_SYSCLK_IN = 10 (ACLK), EN_ANA_CLKIN = 1
w 0x48 194 0x01; //SEL_CLK_DIV = 1/2 (for 49.152/45.1584MHz, this sets ADC clock rate, must be 22
or 24MHz)

w 0 0x00; //OUTPUT_SEL = 00 (I2S)
w 1 0x33; //ENABLE_ADC_CH and ENABLE_DATA_IN_CH
w 2 0x07; //SELECT_ADC_NUM = 7 for 48k/44.1k, 3 for 96k, 1 for 192k
w 3 0x01; //SELECT_IADC_NUM = 1, should match SEL_CLK_DIV
w 8 0x00; //MASTER_BCK_DIV1 = 0, MASTER_MODE_ENABLE = 0
w 9 0x00; //master mode is disabled
w 10 0x05; //TDM_VALID_EDGE = 1, ENALE_TDM_CLK = 1
w 11 0x01; //TDM_CH_NUM = 1 (# of channels = 1 + TDM_CH_NUM)
w 12 0x00; //TDM_LINE_SEL_CH1: 00 (GPIO3), TDM_SLOT_SEL_CH1: 0 (slot 0)
w 13 0x01; //TDM_LINE_SEL_CH2: 00 (GPIO3), TDM_SLOT_SEL_CH2: 1 (slot 1)
w 23 0x0A; //FS_PHASE = 10

//GPIO enabling
w 74 0x11; //GPIO1 and GPIO2 set to AUX input (slave mode)
w 75 0x02; //GPIO3 set to AUX output
w 86 0x03; //GPIO1 and GPIO2 input enabled
w 88 0x04; //GPIO3 output enabled

//ADC CONFIG
w 63 0xBB; //adc ch1a config
w 64 0x38;
w 65 0xBB; //adc ch2a config
w 66 0x38;
w 67 0xBB; //adc ch1b config
w 68 0x38;
w 69 0xBB; //adc ch2b config
w 70 0x38;
w 71 0xFF; //set common mode to 3

//ADC filter and datapath registers
w 113 0x98; //ADC1A_FILTER_SHAPE = Minimum phase slow roll off
w 118 0x01;
w 130 0x98; //ADC2A_FILTER_SHAPE = Minimum phase slow roll off
w 135 0x01;

```



```
w 147 0x98; //ADC1B_FILTER_SHAPE = Minimum phase slow roll off  
w 164 0x98; //ADC2B_FILTER_SHAPE = Minimum phase slow roll off
```



TDM Master

FS=48kHz, 2 Channel, MCLK=49.152MHz

```

w 0x48 193 0x01; //SEL_SYSCLK_IN = 00 (XTAL), EN_ANA_CLKIN = 1
//w 0x48 193 0x05; //SEL_SYSCLK_IN = 10 (ACLK), EN_ANA_CLKIN = 1
w 0x48 194 0x01; //SEL_CLK_DIV = 1/2 (for 49.152/45.1584MHz, this sets ADC clock rate, must be 22
or 24MHz)

w 0 0x40; //OUTPUT_SEL = 10 (TDM)
w 1 0x33; //ENABLE_ADC_CH and ENABLE_DATA_IN_CH
w 2 0x07; //SELECT_ADC_NUM = 7 for 48k/44.1k, 3 for 96k, 1 for 192k
w 3 0x01; //SELECT_IADC_NUM = 1, should match SEL_CLK_DIV
w 8 0x07; //MASTER_BCK_DIV1 = 0, MASTER_MODE_ENABLE = 1
w 9 0x07; //SELECT_I2S_TDM_NUM = 7 for 48k/44.1k, 3 for 96k, 1 for 192k (must match Reg 2)
w 10 0x03; //TDMLJ format: TDM_LJ = 1, TDM_VALID_EDGE = 0, ENABLE_TDM_CLK = 1
//w 10 0x05; //TDMI2S format: TDM_LJ = 0, TDM_VALID_EDGE = 1, ENABLE_TDM_CLK = 1
w 11 0x01; //TDM_CH_NUM = 1 (# of channels = 1 + TDM_CH_NUM)
w 12 0x00; //TDM_LINE_SEL_CH1: 00 (GPIO3), TDM_SLOT_SEL_CH1: 0 (slot 0)
w 13 0x01; //TDM_LINE_SEL_CH2: 00 (GPIO3), TDM_SLOT_SEL_CH2: 1 (slot 1)
w 23 0x0A; //FS_PHASE = 10
w 33 0x95; //TDMLJ format: SYNC_POSEDGE_FRAME = 1
//w 33 0x15; //TDMI2S format: SYNC_POSEDGE_FRAME = 0

//GPIO enabling
w 74 0x22; //GPIO1_CFG and GPIO2_CFG set to AUX output (clocks out)
w 75 0x02; //GPIO3_CFG set to AUX output (data out)
w 86 0x03; //GPIO1_SDB and GPIO2_SDB input enabled
w 88 0x07; //GPIO1_OE and GPIO2_OE and GPIO3_OE output enabled

//ADC CONFIG
w 63 0xBB; //adc ch1a config
w 64 0x38;
w 65 0xBB; //adc ch2a config
w 66 0x38;
w 67 0xBB; //adc ch1b config
w 68 0x38;
w 69 0xBB; //adc ch2b config
w 70 0x38;
w 71 0xFF; //set common mode to 3

//ADC filter and datapath registers
w 113 0x98; //ADC1A_FILTER_SHAPE = Minimum phase slow roll off

```



```
w 118 0x01;  
w 130 0x98; //ADC2A_FILTER_SHAPE = Minimum phase slow roll off  
w 135 0x01;  
w 147 0x98; //ADC1B_FILTER_SHAPE = Minimum phase slow roll off  
w 164 0x98; //ADC2B_FILTER_SHAPE = Minimum phase slow roll off
```



TDM Slave

FS=48kHz, 2 Channel, MCLK=49.152MHz

```
w 0x48 193 0x01; //SEL_SYSCLK_IN = 00 (XTAL), EN_ANA_CLKIN = 1
//w 0x48 193 0x05; //SEL_SYSCLK_IN = 10 (ACLK), EN_ANA_CLKIN = 1
w 0x48 194 0x01; //SEL_CLK_DIV = 1/2 (for 49.152/45.1584MHz, this sets ADC clock rate, must be 22
or 24MHz)

w 0 0x40; //OUTPUT_SEL = 10 (TDM)
w 1 0x33; //ENABLE_ADC_CH and ENABLE_DATA_IN_CH
w 2 0x07; //SELECT_ADC_NUM = 7 for 48k/44.1k, 3 for 96k, 1 for 192k
w 3 0x01; //SELECT_IADC_NUM = 1, should match SEL_CLK_DIV
w 8 0x00; //MASTER_BCK_DIV1 = 0, MASTER_MODE_ENABLE = 0
w 9 0x00; //master mode is disabled
w 10 0x03; //TDMLJ format: TDM_LJ = 1, TDM_VALID_EDGE = 0, ENABLE_TDM_CLK = 1
//w 10 0x05; //TDMI2S format: TDM_LJ = 0, TDM_VALID_EDGE = 1, ENABLE_TDM_CLK = 1
w 11 0x01; //TDM_CH_NUM = 1 (# of channels = 1 + TDM_CH_NUM)
w 12 0x00; //TDM_LINE_SEL_CH1: 00 (GPIO3), TDM_SLOT_SEL_CH1: 0 (slot 0)
w 13 0x01; //TDM_LINE_SEL_CH2: 00 (GPIO3), TDM_SLOT_SEL_CH2: 1 (slot 1)
w 23 0x0A; //FS_PHASE = 10
w 33 0x95; //TDMLJ format: SYNC_POSEDGE_FRAME = 1
//w 33 0x15; //TDMI2S format: SYNC_POSEDGE_FRAME = 0

//GPIO enabling
w 74 0x11; //GPIO1 and GPIO2 set to AUX input (slave mode)
w 75 0x02; //GPIO3 set to AUX output
w 86 0x03; //GPIO1 and GPIO2 input enabled
w 88 0x04; //GPIO3 output enabled

//ADC CONFIG
w 63 0xBB; //adc ch1a config
w 64 0x38;
w 65 0xBB; //adc ch2a config
w 66 0x38;
w 67 0xBB; //adc ch1b config
w 68 0x38;
w 69 0xBB; //adc ch2b config
w 70 0x38;
w 71 0xFF; //set common mode to 3

//ADC filter and datapath registers
w 113 0x98; //ADC1A_FILTER_SHAPE = Minimum phase slow roll off
```



```
w 118 0x01;  
w 130 0x98; //ADC2A_FILTER_SHAPE = Minimum phase slow roll off  
w 135 0x01;  
w 147 0x98; //ADC1B_FILTER_SHAPE = Minimum phase slow roll off  
w 164 0x98; //ADC2B_FILTER_SHAPE = Minimum phase slow roll off
```



Revision History

Current Version 0.3

Rev.	Date	Notes
0.1.1	November 16, 2020	Initial release
0.1.2	December 1, 2020	<ul style="list-style-type: none"> Corrected pin 4 pin description
0.1.3	February 22, 2021	<ul style="list-style-type: none"> Updated Performance data Updated Absolute Maximum Ratings from 5V to 4.75V, no 5V supplies are to be used Updated Recommended Operating Conditions Added Power Up/Down sequences Updated Register 1,63-71,73,135,152 Descriptions Updated Package Drawing, removed ESS symbol
0.1.4	February 24, 2021	<ul style="list-style-type: none"> Updated pin names for ES9311Q reference schematic Swapped ADDR1 & ADDR2 in table in register overview
0.2	April 18, 2021	<ul style="list-style-type: none"> Added Clock Distribution section Added I2S Serial timing table Updated ASP references Updated GPIO section Corrected Register 228 with clip descriptions to register 229 Updated Digital Path diagram to include I2S decoder Added notes on THD compensation Added Clip detection section Digital Output Ports Reserved Reg 105[1],122[1] Updated Register 194 descriptions Updated Register 35,36 Register descriptions Register 112-113, 129-230 Register name change Updated Register 63-71,73 Descriptions
0.2.2	May 12, 2021	<ul style="list-style-type: none"> Updated Register 23 FS_PHASE description. Recommended to set to 7'd10 Updated Register 11 [7] TDM_GPIO456 Updated device markings diagram
0.2.3	June 10, 2021	<ul style="list-style-type: none"> Reserved register 73
0.3	Oct 13, 2021	<ul style="list-style-type: none"> Added clock configuration tables Added minimum MCLK frequency Added Note to pin listing Added 2x mode to clock distribution diagram Added reserved register note to top of register listings Added another note on connecting package pin to DGND Major overall formatting changes Changed Standby power consumption Added Captions to all tables and figures Changed HP filter to DC blocking filter for clarity in Digital Block Diagram Re-organized Digital Features sub-sections and added corresponding register names Added Volume Control section under Digital Signal Path Updated GPIO section Added Addendum with s2m configurations



		<ul style="list-style-type: none"> • Unreserved register 71 • Added PCM digital filter characteristics • Updated IADC clock description • Added ESD protection limits • Corrected Figure 11 ES9311 pin names, pins 16-17, 24-25 • Updated ES9311 reference schematic • Updated Register 64,66,68,70 descriptions
--	--	---

© 2021 ESS Technology, Inc.

ESS IC's are not intended, authorized, or warranted for use as components in military applications, medical devices or life support systems. ESS assumes no liability and disclaims any expressed, implied or statutory warranty for use of ESS IC's in such unsuitable applications.

No part of this publication may be reproduced, stored in a retrieval system, transmitted, or translated in any form or by any means, electronic, mechanical, manual, optical, or otherwise, without the prior written permission of ESS Technology, Inc. ESS Technology, Inc. makes no representations or warranties regarding the content of this document. All specifications are subject to change without prior notice. ESS Technology, Inc. assumes no responsibility for any errors contained herein. U.S. patents pending.