



AG01

Carbon Monoxide Sensing Element

Product Overview

The AG01 carbon monoxide (CO) sensing element is designed to work with the Veris GWN Series gas platform unit to provide accurate monitoring of CO levels. Common sources of CO include automobile exhaust from gasoline engines, gasoline powered furnaces, gasoline powered water heaters, and gasoline generators. The sensor is calibrated at the factory, so no field calibration is needed. The AG01 is warranted to meet accuracy specifications for two years after the date of manufacture.

NOTICE

- This product is not intended for life or safety applications.
- Do not install this product in hazardous or classified locations.
- Read and understand the instructions before installing this product.
- Turn off all power supplying equipment before working on it.
- The installer is responsible for conformance to all applicable codes.

No responsibility is assumed by Veris Industries for any consequences arising out of the use of this material.

Specifications

Sensor Type	Electrochemical
Measurement Range	0-200 ppm
Accuracy	±5% of range
Resolution	1 ppm
Sensor Warranty	2 years from manufacture date
Low Level Setpoint	25 or 35 ppm (switch selectable)
High Level Setpoint	180 ppm (fixed)
Operating Temperature Range	-20° to 50°C (-4° to 122°F)
Operating Humidity Range	0-90% RH noncondensing

The AGxx sensors work only with Veris GWN Series gas platform devices.

Installation



Observe precautions for handling static sensitive devices to avoid damage to the circuitry that is not covered under the factory warranty.

1. Disconnect and lock out all power sources before beginning the installation of the sensor.
2. Install the GWN Series gas platform according to the instructions included with that device.
3. Remove the front cover from the GWN Series gas platform device.
4. Use the grooves on the sides of the AG01 to correctly position the sensor with respect to the GWN unit.
5. Press the connector block on the sensor onto the connector pins on the GWN unit.

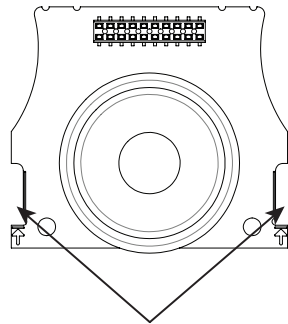

Use these grooves to position the sensor properly before pressing the sensor into the pin connector on the GWN board.

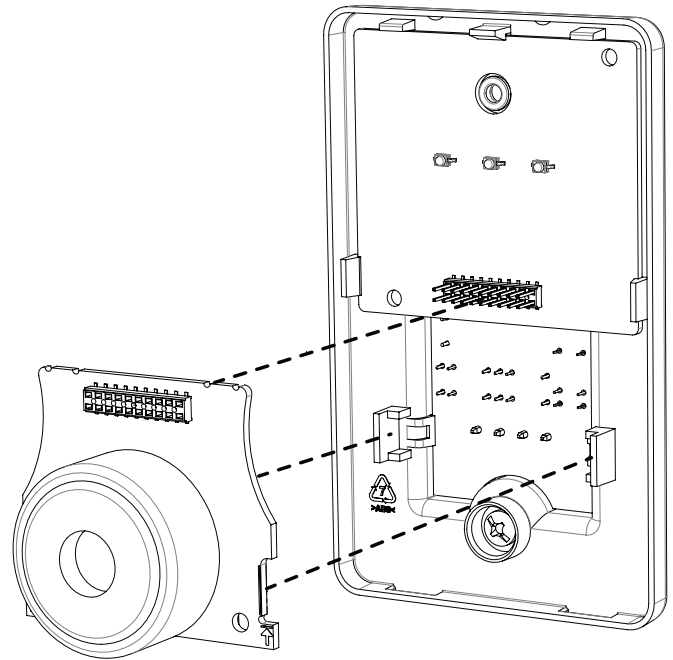

6. The low relay setpoint value of the AG01 sensor is selectable (either 25 or 35 ppm). Use the setpoint selection switch on the GWN board to choose LO (for 25 ppm) or HI (for 35 ppm).

The AG01 high setpoint value is fixed at 200 ppm.

7. Replace the GWN front cover. Reconnect power.