



# LM 3086EPA3 - "STATE OF THE ART" DUST AND OPACITY MONITOR

PROVIDES THE HIGHEST ACCURACY AND LONG-TERM RELIABILITY AVAILABLE FOR OPACITY AND DUST MONITORS

## FEATURES:

- Reliable Laser Technology
- Easy Installation
- Reduced Maintenance
- Unique Simulated Zero and Span Calibration System
- Continuous Control of the Optical Surfaces
- Automatic Shutter
- Meets U.S. EPA 40 CFR Appendix B, PS1 (rev) requirements
- TÜV Approval acc. to the requirements of 13. BlmSchV (Large Combustion Plants) and TA Luft (German Clean Air Act)

## PRINCIPLE OF OPERATION:

The measurement system is based on the single pass/dual path-architecture, illustrated. The laser beam crosses the measurement section only once, with the Receiver measuring and evaluating the change in the laser beam signal strength due to the fluctuations in the particulate content of the Stack. Additionally the Transmitter sends two reference signals, via optical fibre, externally around the stack, to the Receiver at forty times per second. This provides a Continuous measurement of Zero & Span values. This system improves the long-term accuracy of the analyzer. Traditional analyzers of dual-pass design, exclude the retro-reflector from the zero/span calibration. In the LM3086EPA3 analyzer the optical reference path around the stack ensures that all affected surfaces are included in the calibration. The Monitor automatically corrects for dirt that can accumulate on these surfaces.

## ADVANTAGES OF USING OPTICAL REFERENCE PATH:

- Dirt in optics is eliminated from the measurement values, providing real long term accuracy and stability
- Automatic calibration and zero 40 times per second
- Low need of maintenance

## ADVANTAGES OF USING A LASER LIGHT SOURCE:

- Measuring path up to 65 feet without changing a single component in the system, due to a narrow and intense laser light beam
- Excellent beam collimation
- Standard wavelength together with optical reference path guarantees long-term accuracy and stability

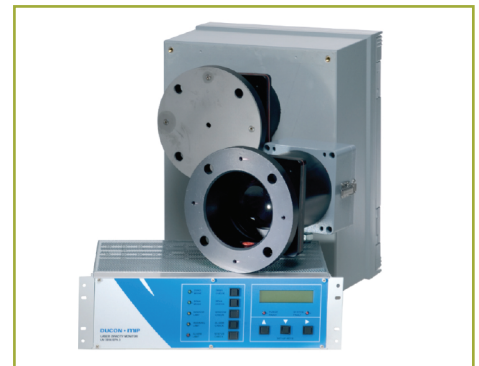
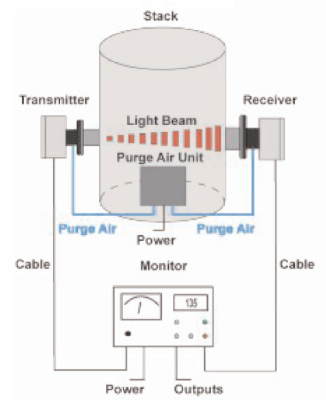

## FEATURES OF THE MONITOR UNIT:

- Auto diagnostic mode is run at the power-up of the monitor and can be triggered manually at any time by the operator
- Continuous system check program runs in the background alerting the operator of exceptions or out of specification parameters
- Comprehensive data storage for measured values and alarms
- Multiple display alternatives for optical and mass readings Flexible output options improve the connectivity with larger control systems



**ISweek** www.isweek.cn

公司名: 深圳市工采网络科技有限公司

电话: +86-755-83289036

地址: 广东省深圳市南山区高新南一道中国科技开发院3号楼16层

传真: +86-755-83289052

邮箱: sales@isweek.cn

**MEASUREMENT FUNCTIONS AND RANGES**

Function	Range	Resolution
Opacity %	0...100%	0...1%
Optical Density	0...3.0	0.001D
Mass/g/m <sup>3</sup>	0...100	1mg/m <sup>3</sup>

**CALIBRATION AND ZERO DRIFT**

PS-1/Test time	1 h	24 h	336 h
Calibration drift	< 0.2%	< 0.2%	< 0.2%
Zero drift	< 0.2%	< 0.2%	< 0.2%

**MONITOR UNIT**

<b>Communication</b>	Analog
<b>Display</b>	Dual 16 character alphanumeric LCD
<b>Controls</b>	Eight pushbutton switches
<b>Alarms and mode Indicators</b>	7 relays with dry contacts and indicator LED's for: Warning limit, Window limit, Cal. mode in process, System fault, Alarm limit, Zero mode in progress, Purge alarm
<b>Outputs/Inputs</b>	CH1: 4...20 mA for real-time opacity CH2: 4...20 mA selectable between the following: Real-time mass concentration mg/m <sup>3</sup> , Averaged opacity, Optical density RS-232 C for printer, PC or mill computer External trigger input for autozero & cal
<b>Operational modes</b>	Diagnostic mode, Autozero & cal mode, Set-up modes, Main monitoring mode, Manual modes, Service/Audit modes
<b>Stored data</b>	128 last averages, 32 last zero values, 2 calibration values, 32 last window values, Audit log, System log (last power loss, stack exit set-up and system fault) (Date and time stored for the last events)
<b>Environmental</b>	Ambient temperature 32...149° F Power 115/230 VAC, 15 VA
<b>Dimensions</b>	size: 19" rack, (19" x 10.5" x 5.2") weight: 8 lbs

**PROCESS PARAMETERS**

<b>Mechanical</b>	4", 150# flange
<b>Stack overpressure, max</b>	25 mbar
<b>Stack temperature, max</b>	1202° F
<b>Purge flow</b>	85...566 l/min
<b>Path length</b>	21.9 yards

**ENVIRONMENTAL (STACK UNITS)**

<b>Ambient temperature</b>	-22 ...+149° F
<b>Power</b>	115/230 VAC, 40 VA
<b>Dimensions/ Laser unit</b>	19.7"x15.7"x9.8" without flange
<b>Dimensions/ Receiver unit</b>	6.3"x6.3"x3.5" without flange
<b>Protection class.</b>	IP 66