

TGS 2442 - for the detection of Carbon Monoxide

Features:

- * Low power consumption
- * High sensitivity/selectivity to carbon monoxide (CO)
- * Miniature size
- * Low sensitivity to alcohol vapor
- * Long life and low cost
- * Low humidity dependency

TGS 2442 utilizes a multilayer sensor structure. A glass layer for thermal insulation is printed between a ruthenium oxide (RuO₂) heater and an alumina substrate. A pair of Au electrodes for the heater are formed on a thermal insulator. The gas sensing layer, which is formed of tin dioxide (SnO₂), is printed on an electrical insulation layer which covers the heater. A pair of Au electrodes for measuring sensor resistance are formed on the electrical insulator. Activated charcoal is filled between the internal cover and the outer cover for the purpose of reducing the influence of noise gases.

TGS 2442 displays good selectivity to carbon monoxide, making it ideal for CO monitors. In the presence of CO, the sensor's conductivity increases depending on the gas concentration in the air. A simple pulsed electrical circuit operating on a one second circuit voltage cycle can convert the change in conductivity to an output signal which corresponds to gas concentration.

The figure below represents typical sensitivity characteristics, all data having been gathered at standard test conditions (see reverse side of this sheet). The Y-axis is indicated as sensor resistance ratio (Rs/Ro) which is defined as follows:

- Rs = Sensor resistance of displayed gases at various concentrations
- Ro = Sensor resistance in 100ppm CO

Sensitivity Characteristics:

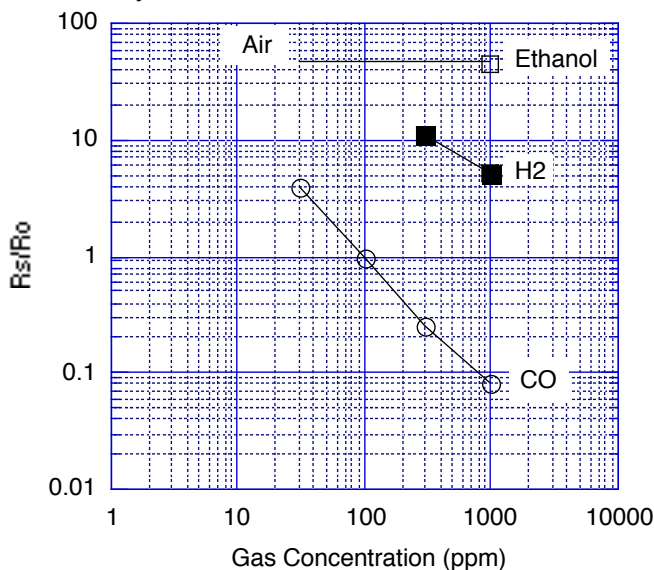

Applications:

- * CO detectors
- * Air quality controllers
- * Indoor parking lot ventilation



The figure below represents typical temperature and humidity dependency characteristics. Again, the Y-axis is indicated as sensor resistance ratio (Rs/Ro), defined as follows:

- Rs = Sensor resistance at 30ppm, 100ppm and 300ppm of CO at various temperatures and 50%R.H.
- Ro = Sensor resistance at 300ppm of CO at 25°C and 50% R.H.

Temperature/Humidity Dependency:

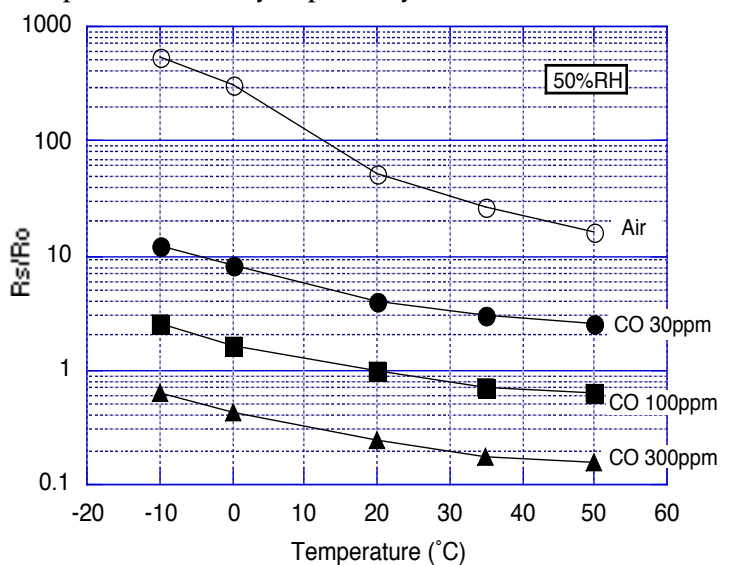

IMPORTANT NOTE: OPERATING CONDITIONS IN WHICH FIGARO SENSORS ARE USED WILL VARY WITH EACH CUSTOMER'S SPECIFIC APPLICATIONS. FIGARO STRONGLY RECOMMENDS CONSULTING OUR TECHNICAL STAFF BEFORE DEPLOYING FIGARO SENSORS IN YOUR APPLICATION AND, IN PARTICULAR, WHEN CUSTOMER'S TARGET GASES ARE NOT LISTED HEREIN. FIGARO CANNOT ASSUME ANY RESPONSIBILITY FOR ANY USE OF ITS SENSORS IN A PRODUCT OR APPLICATION FOR WHICH SENSOR HAS NOT BEEN SPECIFICALLY TESTED BY FIGARO.

Basic Measuring Circuit:

Circuit voltage (Vc) is applied across the sensing element which has a resistance (Rs) between the sensor's two electrodes (pins No. 2 and No. 3) and a load resistor (RL) connected in series. The sensing element is heated by the heater which is connected to pins No. 1 and No. 4.

Heating cycle--The sensor requires application of a 1 second heating cycle which is used in connection with a circuit

voltage cycle of 1 second. Each V_H cycle is comprised by 4.8V being applied to the heater for the first 14ms, followed by 0V pulse for the remaining 986ms. The V_c cycle consists of 0V applied for 995ms, followed by 5.0V for 5ms. For achieving optimal sensing characteristics, the sensor's signal should be measured after the midpoint of the 5ms V_c pulse of 5.0V (for reference, see timing chart below).

NOTE: Application of a V_c pulse condition is required to prevent possible migration of heater materials into the sensing element material. Under extreme conditions of high humidity and temperature, a constant V_c condition could result in such migration and cause long term drift of R_s to higher values. A 5ms V_c pulse results in significantly less driving force for migration than a constant V_c condition, rendering the possibility of migration negligibly small.

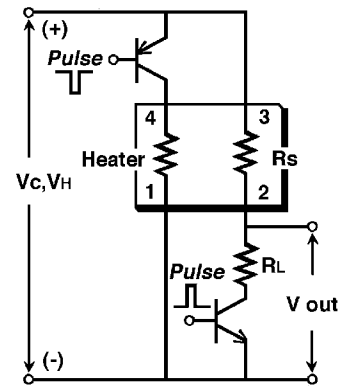
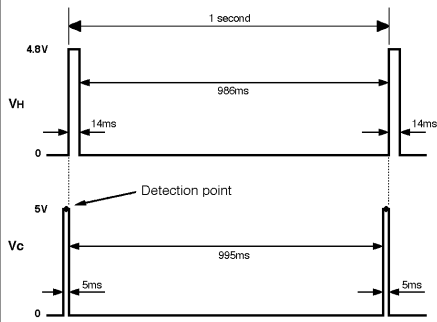

Structure and Dimensions:

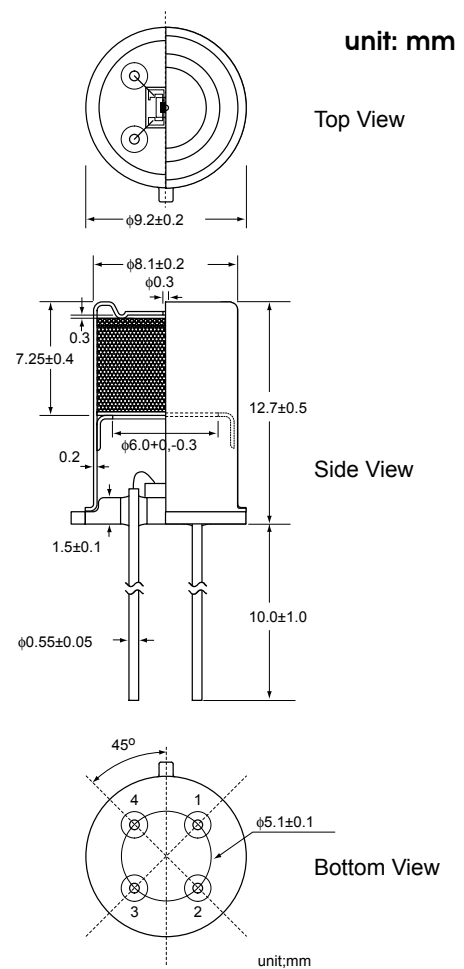

Specifications:

Model number		TGS 2442	
Sensing element type		M1	
Standard package		TO-5 metal can	
Target gases		Carbon monoxide	
Typical detection range		30 ~ 1000 ppm	
Standard circuit conditions	Heater voltage cycle	V _H	V _{HH} =4.8V±0.2V DC, 14ms V _{HL} =0.0, 986ms
	Circuit voltage cycle	V _C	V _C =0V for 995ms, V _C =5.0V±0.2V DC for 5ms
	Load resistance	R _L	variable (≥10kΩ)
Electrical characteristics under standard test conditions	Heater resistance	R _H	17 ± 2.5Ω at room temp.
	Heater current	I _H	approx. 203mA(in case of V _{HH})
	Heater power consumption	P _H	approx. 14mW (ave.)
	Sensor resistance	R _S	13.3kΩ ~ 133kΩ in 100ppm of carbon monoxide
	Sensitivity (change ratio of R _s)	β	0.13 ~ 0.31
Standard test conditions	Test gas conditions	Carbon monoxide in air at 20±2°C, 65±5%RH	
	Circuit conditions	Same as Std. Circuit Condition (above)	
	Conditioning period before test	2 days or more	

Sensor resistance (R_s) is calculated with a measured value of V_{out} as follows:

$$R_s = \frac{V_c \cdot R_L}{V_{out}} - R_L$$

The value of sensitivity (β) is calculated with two measured values of R_s as follows:

$$\beta = \frac{R_s(CO,300ppm)}{R_s(CO,100ppm)}$$